



NEPAL NATIONAL BUILDING CODE

NBC 202 : 1994



MANDATORY RULES OF THUMB LOAD BEARING MASONRY

Government of Nepal
Ministry of Physical Planning and Works
Department of Urban Development and Building Construction
Babar Mahal, Kathmandu, NEPAL
Reprinted : 2064



NEPAL NATIONAL BUILDING CODE

NBC 202 : 1994



MANDATORY RULES OF THUMB LOAD BEARING MASONRY

This publication represents a standard of good practice and therefore takes the form of recommendations. Compliance with it does not confer immunity from relevant legal requirements, including bylaws

तत्कालिन श्री ५ को सरकार (मन्त्रिपरिषद्) को मिति २०६०।४।१२ को निर्णयानुसार स्वीकृत

Government of Nepal
Ministry of Physical Planning and Works
Department of Urban Development and Building Construction
Babar Mahal, Kathmandu, NEPAL
Reprinted : 2064

Preface

This Nepal Standard was prepared during 1993 as part of a project to prepare a National Building Code for Nepal.

In 1988 the Ministry of Housing and Physical Planning (MHPP), conscious of the growing needs of Nepal's urban and shelter sectors, requested technical assistance from the United Nations Development Programme and their executing agency, United Nations Centre for Human Settlements (UNCHS).

A programme of Policy and Technical Support was set up within the Ministry (UNDP Project NEP/88/054) and a number of activities have been undertaken within this framework.

The 1988 earthquake in Nepal, and the resulting deaths and damage to both housing and schools, again drew attention to the need for changes and improvement in current building construction and design methods.

Until now, Nepal has not had any regulations or documents of its own setting out either requirements or good practice for achieving satisfactory strength in buildings.

In late 1991 the MHPP and UNCHS requested proposals for the development of such regulations and documents from international organisations in response to terms of reference prepared by a panel of experts.

This document has been prepared by the subcontractor's team working within the Department of Building, the team including members of the Department and the MHPP. As part of the proposed management and implementation strategy, it has been prepared so as to conform with the general presentation requirements of the Nepal Bureau of Standards and Metrology.

The subproject has been undertaken under the aegis of an Advisory Panel to the MHPP.

The Advisory Panel consisted of :

Mr. UB Malla, Joint Secretary, MHPP Director General, Department of Building (Mr. LR Upadhyay)	Chairman
Mr. AR Pant, Under Secretary, MHPP Director General, Department of Mines & Geology (Mr. PL Shrestha)	Member
Mr. AR Pant, Under Secretary, MHPP Director General, Department of Mines & Geology (Mr. PL Shrestha)	Member
Director General, Nepal Bureau of Standards & Metrology (Mr. PB Manandhar)	Member
Dean, Institute of Engineering, Tribhuvan University (Dr. SB Mathe)	Member
Project Chief, Earthquake Areas Rehabilitation & Reconstruction Project	Member
President, Nepal Engineers Association	Member
Law Officer, MHPP (Mr. RB Dange)	Member
Representative, Society of Consulting Architectural & Engineering Firms (SCAEF)	Member

Representative, Society of Nepalese Architects (SONA)
Deputy Director General, Department of Building,
(Mr. JP Pradhan)

Member
Member-Secretary

The Subcontractor was BECA WORLEY INTERNATIONAL CONSULTANTS LTD. of New Zealand in conjunction with subconsultants who included :

Golder Associates Ltd., Canada
SILT Consultants P. Ltd., Nepal
TAEC Consult (P.) Ltd., Nepal
Urban Regional Research, USA

Principal inputs to this standard came from :

Mr. AM Tuladhar, DoB, HMGN
Dr. AS Arya, Professor Emeritus, University of Roorkee
Mr. YK Parajuli, TAEC
Mr. JR Pokharel, TAEC
Mr. JK Bothara, TAEC
Dr. RD Sharpe, BECA (Team Leader)

Revisions and Updated to this code came from:

Mr. Purna P. Kadariya, DG, DUDBC
Mr. Kishore Thapa, DDG, DUDBC
Mr. Mani Ratna Tuladhar, Sr. Div. Engineer, DUDBC
Mr. Jyoti Prasad Pradhan, Ex. DG, DOB
Mr. Bhubaneswor Lal Shrestha, Ex. DDG, DOB
Mr. Uttam Shrestha, Architect, Architects' Module Pvt. Ltd.
Mr. Manohar Lal Rajbhandrai, Sr. Structural Engineer, MR Associates
Mr. Amrit Man Tuladhar, Civil Engineer, DUDBC

TABLE OF CONTENTS

Preface		i
0 Foreword		vi
0.1 Design Aspect		vi
0.2 Objective		vi
0.3 Limitations		vi
0.4 Intended Users		vii
0.5 Alternative Materials and Construction		vii
0.6 What are Non-Engineered Buildings ?		vii
0.7 Related References		vii
1 Scope		1
1.1 Applicability		1
1.2 Limitations		1
2 Interpretation		5
2.1 General		5
2.2 Terminology		5
3 Materials		5
3.1 Concrete		5
3.2 Brick Masonry		5
4 General Concepts for Earthquake Resistance		7
4.1 Categories of Buildings		7
4.2 Seismic Zones		7
4.3 Importance of the Building		7
5 Selection and Investigation of the Site		9
5.1 General		9
5.2 Use of Local Knowledge		9
5.3 Site Investigation Requirements		9
5.4 Allowable Bearing Pressure		9
6 Combination of Parameters		11
7 General Construction Aspects		12
7.1 Openings in Walls		12

7.2	Masonry Bond	12
7.3	Mortars and Concrete	12
7.4	Vertical Joints Between Orthogonal Walls	12
8	Horizontal Reinforcement in Walls	16
8.1	Horizontal Bands or Ring Beams	16
8.2	Plinth Band	16
8.3	Lintel Band	16
8.4	Roof Band	17
8.5	Gable Band	17
	8.5.1 Section of Bands or Ring Beams	17
9	Dowels at Corners and Junctions	21
10	Vertical Reinforcement in Walls	25
11	Roof.....	27
11.1	Pitched Roofs	27
11.2	Trussed Roofs	27
11.3	Lean-to Roofs	28
12	Reinforcement Details for Hollow Block Masonry	29
12.1	Horizontal Band	29
12.2	Vertical Reinforcement	29
	MANDATORY RULE OF THUMB FOR STONE MASONRY BUILDINGS	31
13	Overall Dimensions	31
14	Openings in Walls.....	31
15	Masonry Bond.....	33
	15.1 Mortars and Concrete	33
16	Horizontal Reinforcement in the Walls.....	36
17	Vertical Reinforcement in Walls	38
	MANDATORY RULE OF THUMB FOR BRICK MASONRY BUILDINGS CONSTRUCTED IN MUD MORTAR	40
18	Width of Footing.....	40
19	Height of Wall	40

20	Openings in Walls	40
21	Bearing Length	41
22	Collar Beams or Horizontal Bands	41
23	Pilasters and Buttresses	44
24	Vertical Wood or Bamboo Reinforcement in the Walls	44
25	Roofing	47

0. Foreword

0.1 Design Aspect

Most of the loss of life in past earthquakes in Nepal has occurred due to the collapse of buildings constructed in traditional materials such as brick, stone, wood, mud and adobe and which were not specifically engineered (not designed for structural safety) to be earthquake-resistant. Thus, it is very necessary to introduce earthquake-resistant features in to non-engineered buildings during their construction.

0.2 Objective

The objective of these **Mandatory Rules of Thumb (MRT)** is to achieve the appropriate earthquake-resistant design of those buildings in Nepal which are :

- not normally engineered
- constructed of fired brick or stone masonry in cement or mud mortars
- not more than two storeys high if built in stone masonry in cement mortar or fired brick in mud masonry
- not more than three storeys high if built of fired brick in a cement mortar.

This document includes suitable illustrations to explain the important points, sketches and sufficient data to proportion the critical strength elements correctly. The requirements are based on pre-engineered design calculations of typical structures meeting prescribed criteria.

Other Standards provide similar rules of thumb for common building types such as reinforced concrete framed structures of limited size.

0.3 Limitations

- (i) The requirements set forth in this Standard are applicable only for buildings complying with the specified limitations. The Standard only intends to achieve minimum acceptable structural safety, even though it is always preferable to undertake specific design investigations and design. Owners and builders are, however, encouraged to use the services of competent professional designers for better economy and tailor-made detailing. In such cases, the requirements stated here should be construed as advisory.
- (ii) The provisions of this Standard should be construed as advisory when undertaking the repairs, alterations and additions necessary for the conservation, preservation, restoration, rehabilitation, reconstruction or continued use of structures of archaeological significance.

0.4 Intended Users

This MRT is intended to cater primarily to the requirements of mid-level technicians (overseers and draughtspersons) who are not trained to undertake independently the structural design of buildings. However, professional designers could also use this Standard for an effective utilisation of their time by using the design procedure outlined here.

0.5 Alternative Materials and Construction

The provisions of this standard are not intended to prevent the use of alternative materials and methods of construction if such materials and methods are specifically prescribed by competent professional designers or other competent authorities equivalent to, or better than, those specified here.

0.6 What are Non-Engineered Buildings ?

The term *non-engineered buildings* may be defined as describing those buildings which are spontaneously and informally constructed in the traditional manner without intervention by qualified Engineers or Architects in their design. However, they may follow a set of recommendations derived from the observed behaviour of such buildings. Unless strengthened, such buildings are dangerous in Nepal where earthquake areas can experience ground shaking of intensity VIII or more on the Modified Mercalli Scale.

0.7 Related References

"Guidelines for Earthquake-Resistant Non-Engineered Construction", The International Association for Earthquake Engineering, Revised Edition of Basic Concept of Seismic Codes, Vol. I, Part 2, October 1986.

1 Scope

1.1 Applicability

These Mandatory Rules of Thumb (MRT) cover load-bearing masonry buildings meeting prescribed criteria. They do not cover wooden buildings, mud buildings (low-strength buildings), or those constructed in adobe. No attempt should be made to apply these rules to these latter buildings.

1.2 Limitations

This MRT is valid (with certain limitations as to span, floor height, etc., as prescribed in **Table 1.1**) for :

- i) Up to three-storeyed load-bearing brick (and other rectangular building units) masonry buildings constructed in cement mortars.
- ii) Up to two-storeyed load-bearing stone masonry buildings constructed in cement mortar.
- iii) Up to two-storeyed load-bearing brick masonry buildings constructed in mud mortar.

However, these limitations shall not bar anyone wishing to employ qualified professionals to produce an appropriate design. Structures falling outside these limitations will require the appropriate specific design as may be prescribed by the territorial authority in which they are to be located.

TABLE 1.1 : BUILDING SIZE LIMITATIONS

	Floor	Min. Wall Thickness (mm)	Max. Height (m)	Max. Short Span of Floor (m)	Canti- lever (m)
Load-Bearing Brick Masonry in Cement Mortar	2nd	230	2.8	3.5	1.0
	1st	230	3.0	3.5	1.0
	Ground	350	3.2	3.5	No
Load-Bearing Stone Masonry in Cement Mortar, or Load-Bearing Brick Masonry in Mud Mortar	1st	350	3.0	3.2	No
	Ground	400	3.2	3.2	No
Load Bearing Brick Masonry in Mud Mortar	1st	350	3.0	3.2	No
	Ground	350	3.2	3.2	No

NOTE : See Figures 1.1, 1.2 and 1.3 also.

FOR ONE STOREY ONLY

Brick masonry in cement sand mortar (1:6)

Stone masonry in cement sand mortar (1:6)

Brick masonry in mud mortar

i) Foundation

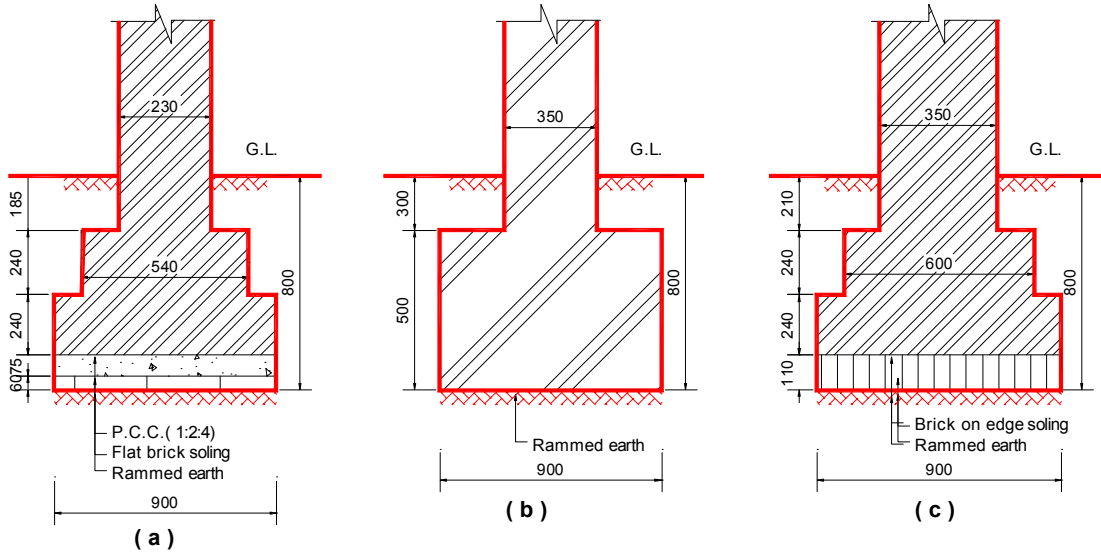

ii) Plinth Level

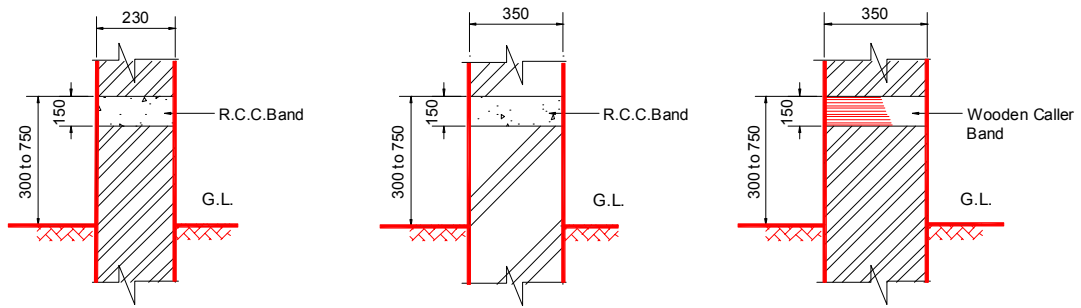

iii) Wall thickness

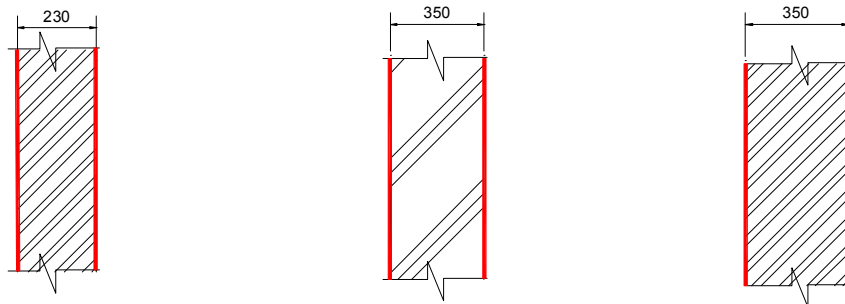

Figure 1.1 Limitation for One-Storey Building

UPTO THREE STOREYED

UP TO TWO STOREYED ONLY

Brick masonry in cement sand mortar (1:6)

Stone masonry in cement sand mortar (1:6)

Brick masonry in mud mortar

i) Foundation

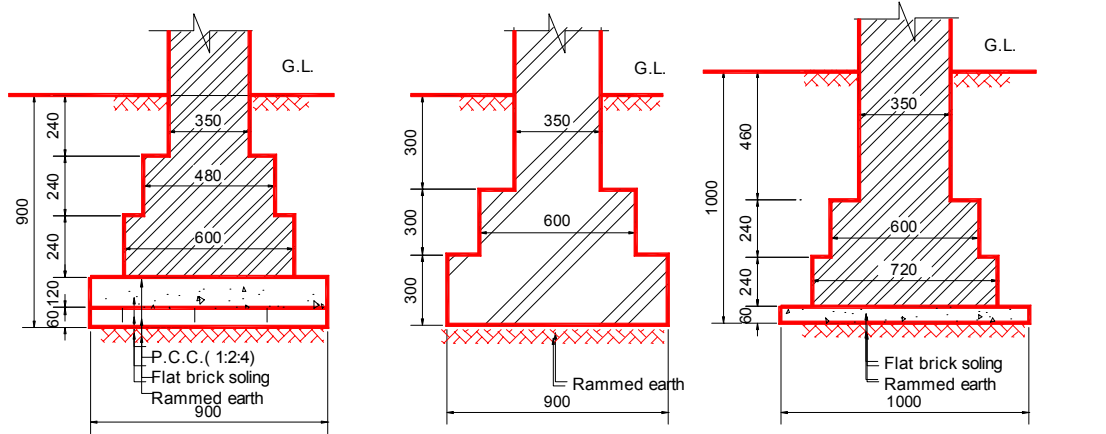

ii) Plinth Level

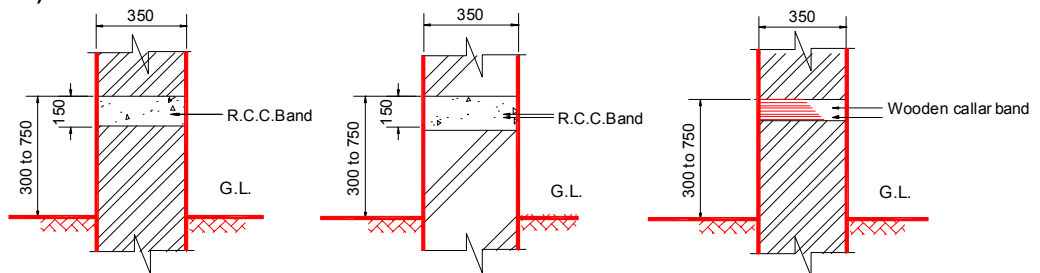

iii) From P. L. to F. F.

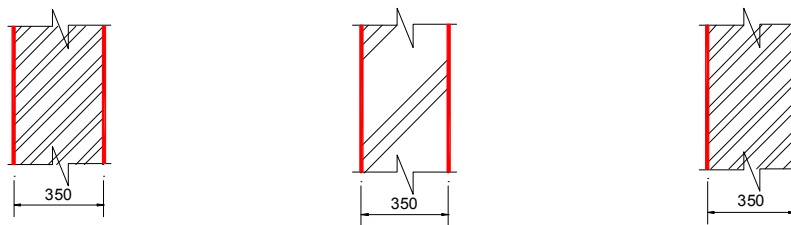

iv) From F.F. to Top Floor

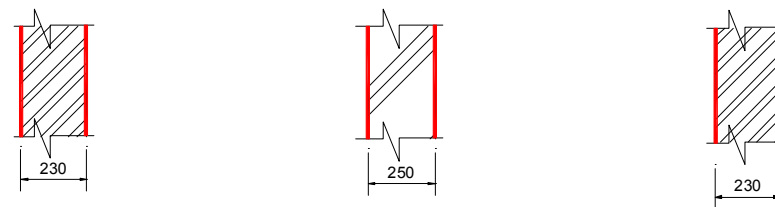

Figures 1.2 & 1.3 : Limitations for Three and Two-Storeyed Buildings

2 Interpretation

2.1 General

2.1.1 In this MRT, the word 'shall' indicates a requirement that is to be adopted order to comply with the provisions of this document, while the word 'should' indicates recommended practice.

2.1.2 Words implying the singular only also include the plural and vice versa wherever the context requires this.

2.2 Terminology

In this Standard, unless inconsistent with the context, the following definition shall apply :

REINFORCEMENT :

- (i) **Mild steel bars** : Conforming to NS 84-2042 or IS:432-1966 (Part I) with $f_y = 250 \text{ N/mm}^2$ (Fe250 Grade).
- (ii) **High Strength Bars** : (Cold-worked deformed bars) conforming to NS 191-2046 or IS:1139-1966 or IS:1786-1979 with $f_y = 415 \text{ N/mm}^2$ (Fe415 Grade) shall be used for reinforcing the masonry and concrete.
- (iii) **High Strength Bars - 550** : High strength bars conforming to NS 191-2046 with $f_y = 550 \text{ N/mm}^2$ (Fe550 Grade)

3 Materials

3.1 Concrete

The concrete to be used in footings, columns, beams and slabs, etc., shall have a minimum crushing strength of 15 kN/m^2 at 28 days for a 150 mm cube.

Note : Where adequate care has been taken in the following : the selection of materials; mixing; correct proportioning; proper placing; compacting and curing of the concrete, a nominal mix of 1:2:4 (cement - coarse sand - coarse stone aggregate) is expected to meet the strength requirements.

3.2 Brick Masonry

All brick masonry shall be built in a tradesman-like manner using the best practices and workmanship that include :

- pre-soaking of bricks in water
- level bedding planes fully covered with mortar
- vertical joints broken from course to course and filled fully with mortar.

Bricks : The bricks shall be of a standard rectangular shape, burnt red, hand-formed or machine-made, and with a crushing strength not less than 3.5 N/mm^2 . The higher the density and the strength, the better they will be. The standard brick size of $240 \times 115 \times 57 \text{ mm}$ with 10 mm thick horizontal and vertical mortar joints is preferable. Tolerances of -10 mm on length, -5 mm on width and $\pm 3 \text{ mm}$ on thickness shall be acceptable for the purpose of walls of the thickness specified in this Standard.

Wall Thickness : A minimum thickness of one half-brick (115 mm) and a maximum thickness of one brick (240 mm) shall be used for the walls constructed as non load-bearing walls in these buildings.

Mortar : Cement-sand mixes of 1:6 and 1:4 shall be adopted for one-brick and half-brick thick walls, respectively. The addition of small quantities of freshly hydrated lime to the mortar in a lime-cement ratio of $\frac{1}{4}:1$ to $\frac{1}{2}:1$ will increase its plasticity greatly without reducing its strength.

Plaster : All plasters shall have a cement-sand mix not leaner than 1:6 on outside or inside faces. It shall have a minimum 28 days cube crushing strength of 3 N/mm^2 . A minimum plaster thickness of 10 mm shall be adopted.

4 General Concepts for Earthquake Resistance

4.1 Categories of Buildings

For categorising the buildings with the purpose of achieving seismic resistance at an economical cost, three parameters are considered to be significant :

- i) Seismic intensity zone where the building is located,
- ii) Importance of the building, and
- iii) Stiffness of the foundation soil.

A combination of these parameters will determine the extent of the appropriate seismic strength of the building.

4.2 Seismic Zones

The seismic zones for Nepal for the purposes of this MRT are described in **Figure 4.1**. They are also categorised here with respect to risk of damage :

Zone A : Risk of widespread collapse and heavy damage.

Zone B : Risk of Moderate damage.

Zone C : Risk of Minor damage.

Note : Zones A, B, C are as per Figure 4.1.

4.3 Importance of the Building

The importance of the building should be a factor in grading it for strengthening purposes. Buildings to be designed using this MRT should be categorised as either 'important' or 'ordinary' :

Important Building means a building which either houses facilities essential before and after a disaster (eg., hospitals, fire and police stations, communication centres, etc.), or which by its very purpose has to house large numbers of people at one time (eg., cinema halls, schools, convention centres, etc.), or which has special national and international importance (eg., palaces, etc.), or which houses hazardous facilities (eg., toxic or explosive facilities, etc.).

Ordinary Building means any building which is not an *important building* (eg., residential, general commercial, ordinary offices, etc.).

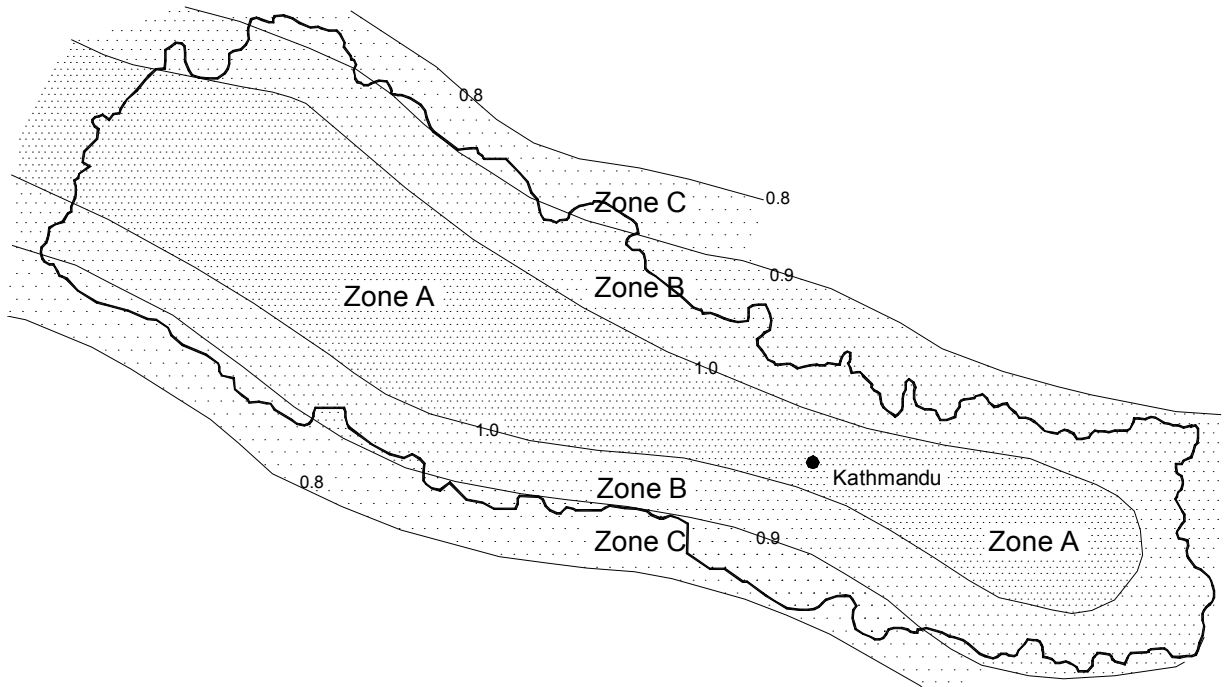

Figure 4.1 : Seismic Zoning Map of Nepal for this MRT

5 Selection and Investigation of the Site

5.1 General

This section sets out some of the requirements to be considered during site selection for the construction of buildings in order to minimise the risks to the buildings from primary geological as well as secondary seismic hazards such as fault rupture, landslides and liquefaction. A building shall not be constructed if the proposed site is :

- Water-logged
- A rock-falling area
- A landslide-prone area
- A subsidence and/or fill area
- A river bed or swamp area

5.2 Use of Local Knowledge

It is a good practice during the construction of a building to examine the existing local knowledge and the history of the performance of existing buildings. This will assist in identifying whether there is any danger from inherent natural susceptibilities of the land to the processes of sliding, erosion, land subsidence and liquefaction during the past earthquakes or any other natural/geological processes likely to threaten the integrity of the building. The local practice of managing such hazards, if any, should be judged against the required level of acceptable risk.

5.3 Site Investigation Requirements

Site exploration shall be carried out by digging test pits, two as a minimum, and more if the subsurface soil condition shows a significant variation in soil type.

Generally, the minimum depth of exploration for a building covered by this MRT shall be 2 m. In hilly areas, exploration up to the depth of sound bed-rock, if it lies shallower than 2 m, should suffice.

No exploration shall be required if the site is located on rock or on fluvial terraces (Tar) with boulder beds.

The soils encountered in the test pits should be classified as per **Table 5.1**.

5.4 Allowable Bearing Pressure

The allowable bearing pressure that can be used is given in **Table 5.1** in conjunction with the visual classification of the subsurface soil type.

TABLE 5.1 : CLASSIFICATION OF FOUNDATION SOIL AND SAFE BEARING CAPACITY

	Type of Foundation Materials	Foundation Classification	Presumed Safe Bearing Capacity, kN/m ²
1.	Rocks in different state of weathering, boulder bed, gravel, sandy gravel and sand-gravel mixture, dense or loose coarse to medium sand offering high resistance to penetration when excavated by tools; stiff to medium clay which is readily indented with a thumb nail	Hard	≥ 200
2.	Fine sand and silt (dry lumps easily pulverised by the fingers); moist clay and sand-clay mixture which can be indented with strong thumb pressure	Medium	≥ 150 and < 200
3.	Fine sand, loose and dry; soft clay indented with moderate thumb pressure	Soft	≥ 100 and < 150
4.	Very soft clay which can be penetrated several centimetres with the thumb, wet clays	Weak	≥ 50 and < 100

Buildings can be constructed on hard, medium and soft soils, but it will be dangerous to build them on weak soils. Hence, appropriate soil investigations should be carried out to establish the allowable bearing capacity and nature of soil. Weak soils must be avoided or compacted to improve them so that they can qualify as 'medium' or 'soft'.

6 Combination of Parameters

For determining the categories of building for seismic strengthening purposes, four categories (I to IV) are defined as per the IAEE book, including the important buildings. Excluding that of important buildings, suitable definitions of the three lower categories (II, III and IV) for Nepal are described in **Table 6.1**. Of all the categories, category I will require the maximum strengthening and category IV the least input. The general planning and designing principles are, however, equally applicable to them all.

TABLE 6.1 : CATEGORIES OF BUILDINGS FOR SEISMIC STRENGTHENING PURPOSES

Category	Combination of Condition for the Category
I	Important Building on soft soil in Zone A*
II	Residential-cum-shop Building on Soft Soil in Zone*
III	Residential-cum-shop Building on Firm Soil in Zone A* Residential-cum-shop Building on Soft Soil in Zone B*
IV	Residential-cum-shop Building on Firm Soil in Zone B* Residential-cum-shop Building on Firm Soil in Zone C* Residential-cum-shop Building on Soft Soil in Zone C*

Important buildings in Category I (eg., Hospitals, Theatres, etc.) shall be designed by a competent professional designer.

* Zone : As per Seismic Zoning map of Nepal (**Figure 4.1**).

7 General Construction Aspects

7.1 Openings in Walls

Any opening in the wall should be small in size and centrally located. The following are the guidelines for the size and position of openings.

- i) Openings are to be located away from inside corners by a clear distance equal to at least 1/4 of the height of the opening, but not less than 600 mm.
- ii) The total length of openings in a wall are not to exceed 50 % of the length of the wall between consecutive cross-walls in single-storey construction, 42 % in two-storey construction, and 33 % in three-storey buildings.
- iii) The horizontal distance (pier width) between two openings is to be not less than one half of the height of the shorter opening (see **Figure 7.1**), but not less than 600 mm.
- iv) The vertical distance from one opening to another opening directly above it shall not be less than 600 mm, nor less than one half the width of the smaller opening (see **Figure 7.2**).
- v) When an opening does not comply with requirements (i) to (iv), it shall be boxed in reinforced jambs through the masonry (**Figure 7.2**).
- vi) If the vertical opening of the wall is more than 50 % of the wall height, vertical bars shall be provided in the jambs.

7.2 Masonry Bond

In order to achieve the full strength of masonry, the usual bonds specified for masonry shall be followed so that the vertical joints are broken properly from course to course.

7.3 Mortars and Concrete

Where steel reinforcing bars are provided, the bars shall be embedded in a cement-sand mortar not leaner than 1:4, or in a cement concrete mix of 1:2:4 (**M15 Grade**).

7.4 Vertical Joints Between Orthogonal Walls

For convenience of construction, builders prefer to make a toothed joint which is later often left hollow and weak. To obtain full bond, it is necessary to make a sloped or stepped joint. It should be constructed so as to obtain full bond by making the corners first to a height of 600 mm, and then building the wall in between them. Alternatively, the toothed joint shall be made in both the walls in lifts of about 450 mm, as shown in **Figure 7.3**.

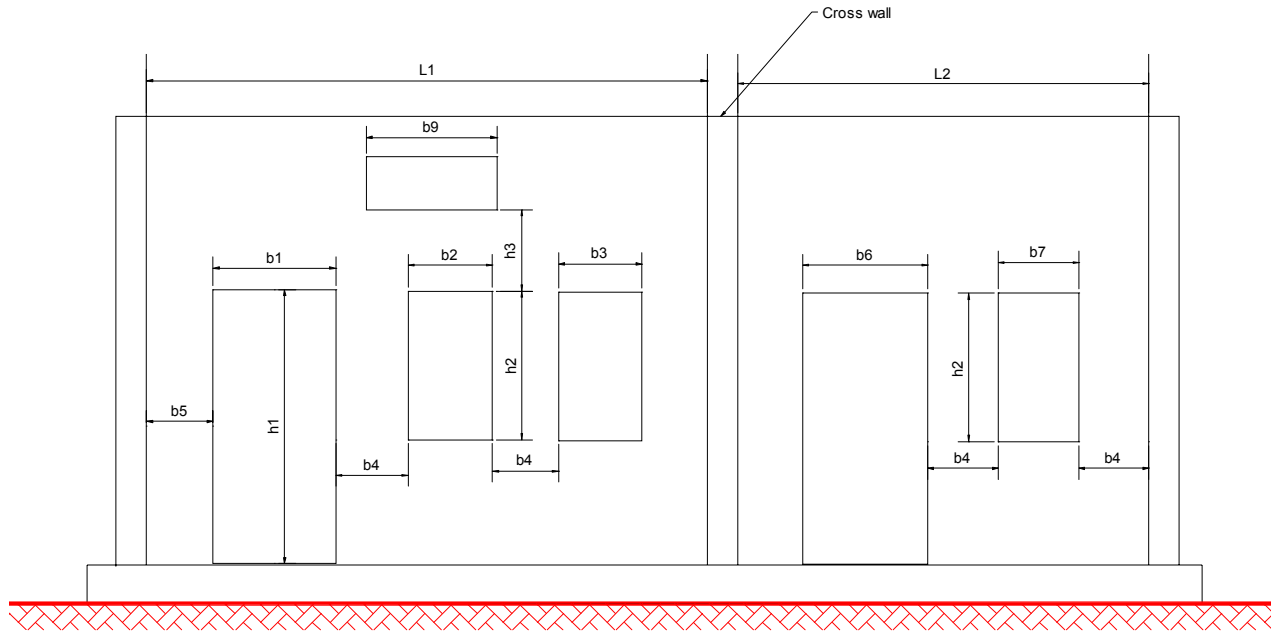
**NOTE:**

$b1 + b2 + b3 < 0.5 L1$ for one storey, $0.42 L1$ for two storeyed, $0.33 L1$ for three storeyed.

$b6 + b7 < 0.5 L2$ for one storey, $0.42 L2$ for two storeyed, $0.33 L2$ for three storeyed.

$b4 > 0.5 h2$ but not less than 600 mm.

$b5 > 0.25 h$ but not less than 600 mm.

$h3 > 600$ mm or $0.5 (b2 \text{ or } b9 \text{ whichever is max })$.

Figure 7.1 : Recommendation Regarding Openings in Bearing Walls

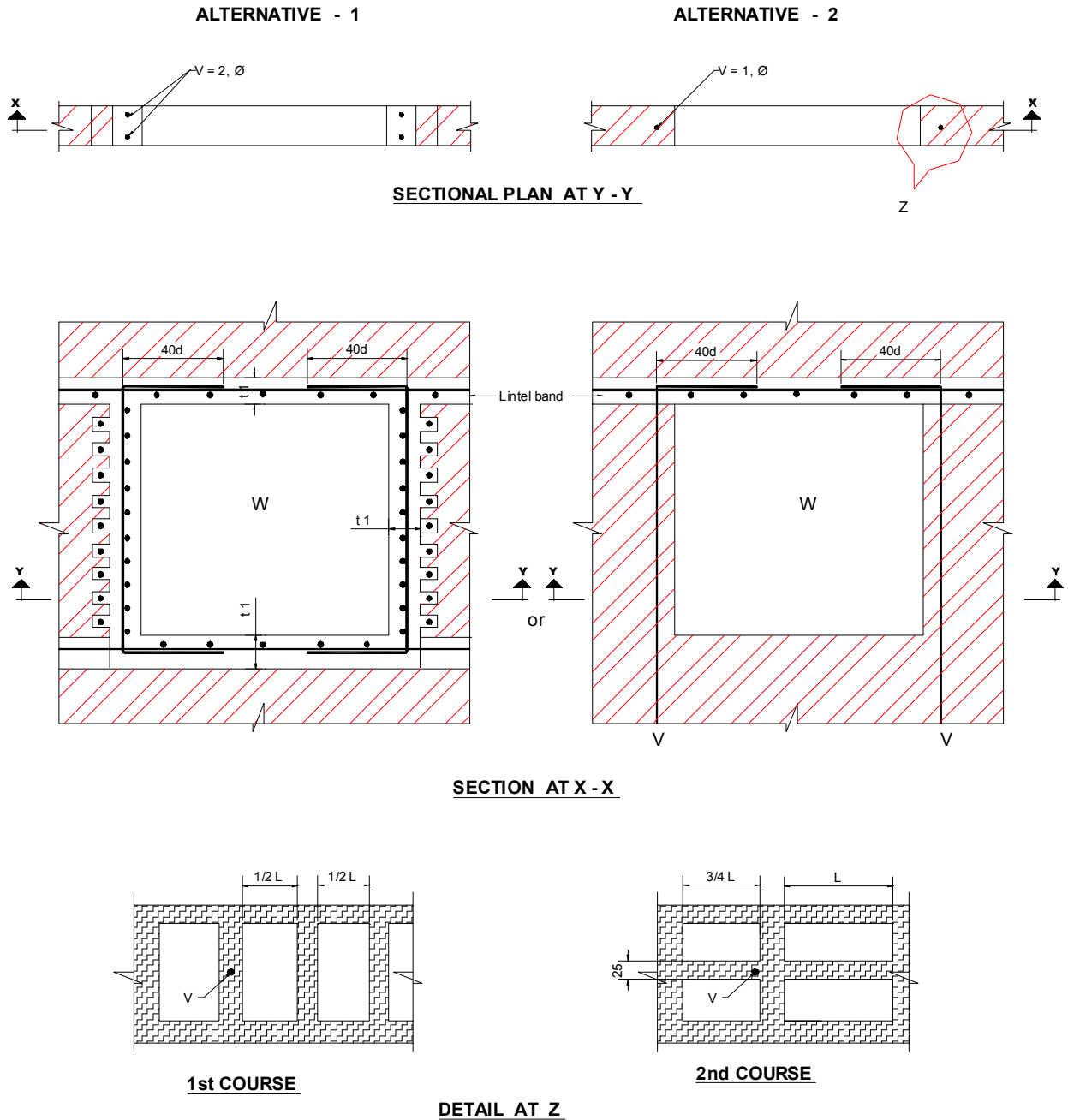

\varnothing - Diameter, W - Window, V - Vertical Reinforcement bars,

t - Thickness of wall (minimum 1 brick length),

t1 - Minimum thickness 75 mm., L - Length of brick unit.

Figure 7.2 : Strengthening of Masonry Around Openings

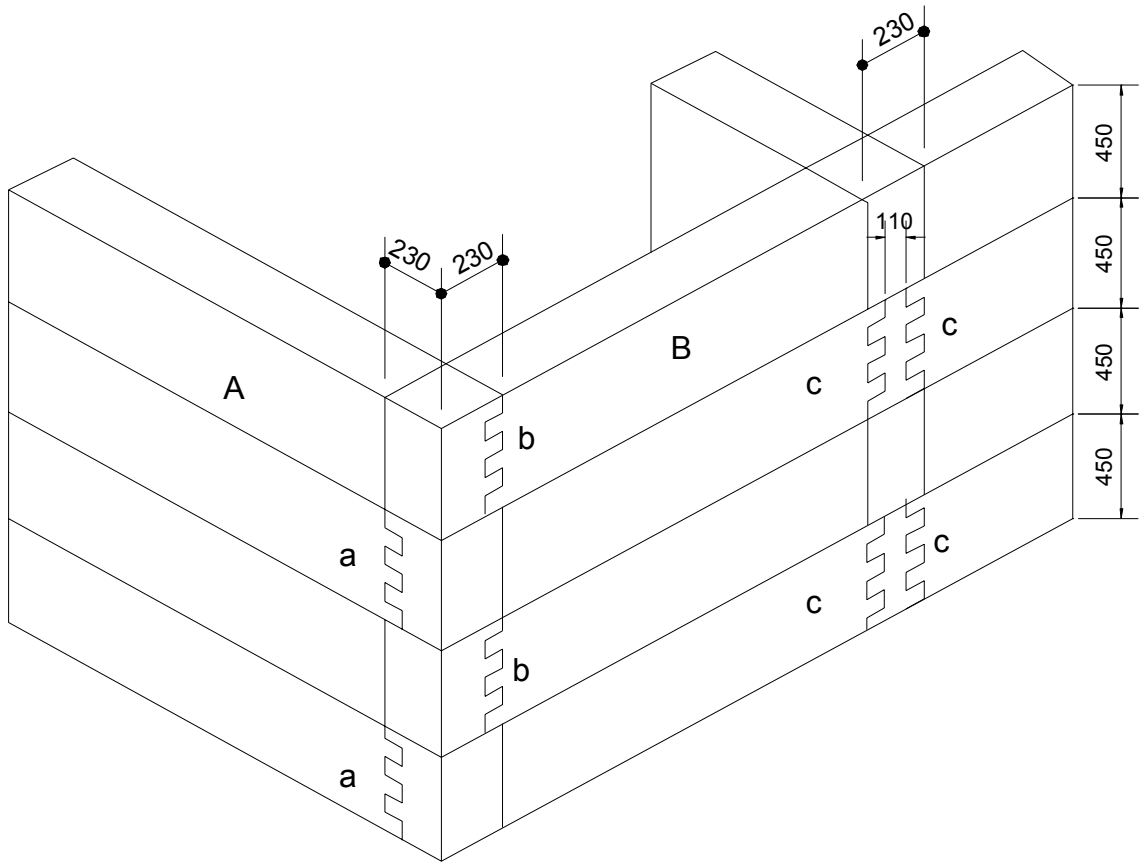

All dimensions are in mm.

a, b, c Toothed joint in walls A, B and C

(Alternating toothed joint in walls at corner and T-junctions)

Figure 7.3 : A Typical Masonry Joint Detail

8 Horizontal Reinforcement in Walls

Horizontal reinforcing of walls is required in order to tie orthogonal walls together.

8.1 Horizontal Bands or Ring Beams

The most important horizontal reinforcing is by means of reinforced concrete bands provided continuously through all load-bearing longitudinal and transverse walls at plinth, lintel and roof-eave levels, and also at the top of gables according to the requirements stated below.

8.2 Plinth Band

This should be provided in those cases where the soil is soft or uneven in its properties. It may also serve as a damp-proof course.

8.3 Lintel Band

A lintel band shall be incorporated in all openings. The reinforcement over the openings shall be provided in addition to that of any other requirement. It must be provided in all storeys in all buildings as per **Table 8.1** :

TABLE 8.1 : REQUIREMENT FOR STEEL IN RC BAND

Span of walls between cross-walls (m)	Category II			Category III			Category IV		
	No. of Bars	Diameter of Bars (mm)		No. of Bars	Diameter of Bars (mm)		No. of Bars	Diameter of Bars (mm)	
		T	K		T	K		T	K
5 or less	2	10	9	2	10	9	2	10	9
6	2	12	10	2	10	9	2	10	9

where :

T = High Strength bars having $f_y = 415 \text{ N/mm}^2$

K = High Strength bars having $f_y = 550 \text{ N/mm}^2$

(See following page for Notes)

Notes :

1. *The width of the RC band is assumed to be the same as the thickness of the wall. The minimum thickness of a load-bearing wall shall be 230 mm. A cover of 25 mm from the face of wall shall be maintained for all steel reinforcing.*
2. *The vertical thickness of the RC band may be kept to a minimum of 75 mm where two longitudinal bars are specified, and to 150 mm where four longitudinal bars are specified.*
3. *The concrete mix is to be 1:2:4 by volume. Alternatively, it shall have an M15 Grade cube crushing strength at 28 days.*
4. *The longitudinal bars shall be held in position by steel stirrups 6 mm in diameter (or 5 mm diameter if Grade Fe550) spaced 150 mm apart.*

8.4 Roof Band

This band shall be provided at the eave-level of trussed roofs (**Figure 8.2**) and also below gable levels on such floors which consist of joists and covering elements - so as to integrate them properly at their ends and fix them into the walls.

8.5 Gable Band

Masonry gable ends must have the triangular portion of masonry enclosed in a band, the horizontal part of which will be continuous with the eave-level band on the adjacent longitudinal walls (**Figure 8.2**).

8.5.1 Section of Bands or Ring Beams

The reinforcement and dimensions of these bands shall be made as per **Table 8.1**.

A band shall consist of two (or four) longitudinal steel bars with stirrups embedded in 75 mm (or 150 mm) thick concrete (**Figure 8.3**). The thickness of the band shall be made equal to, or a multiple of, the masonry unit and its width shall equal the thickness of the wall. The steel bars shall be located close to the wall faces with 25 mm of cover, and full continuity of steel shall be provided around corners and through junctions.

The minimum steel requirements for various buildings for these bands or ring beams are shown in **Table 8.1**. Such bands are to be located at critical levels of the building, namely at the plinth, lintel, roof and gable according to the requirements specified above in **Clauses 7.1 to 7.4**.

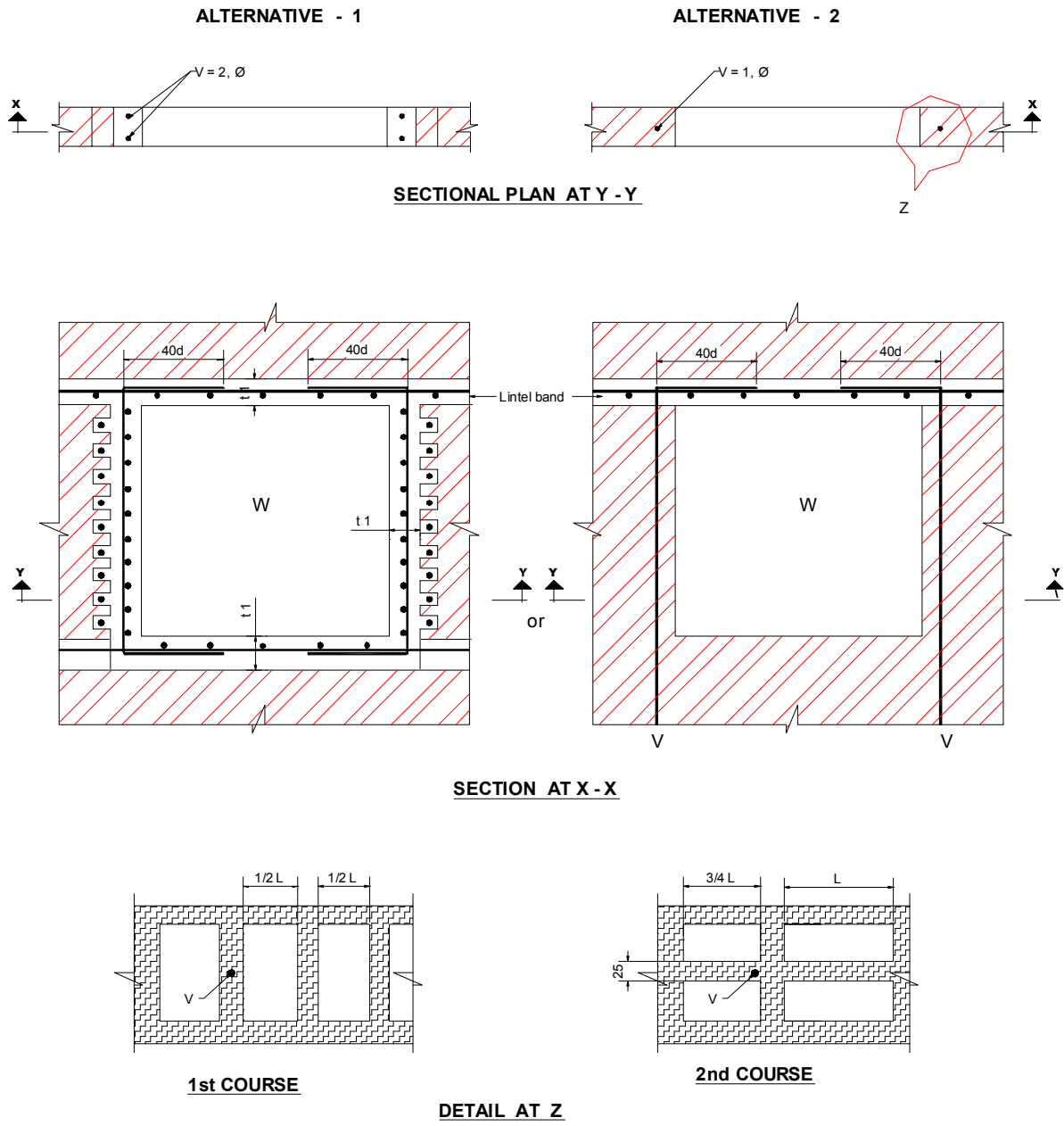

Ø - Diameter, W - Window, V - Vertical Reinforcement bars,
 t - Thickness of wall (minimum 1 brick length),
 t1 - Minimum thickness 75 mm., L - Length of brick unit.

Figure 8.1 : Gable Band and Roof Band in Barrack-Type Buildings

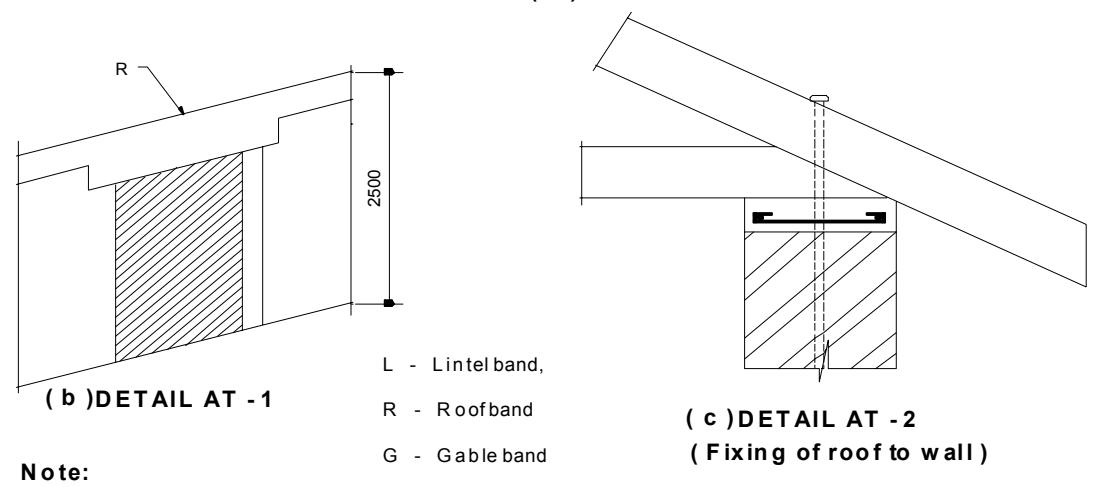
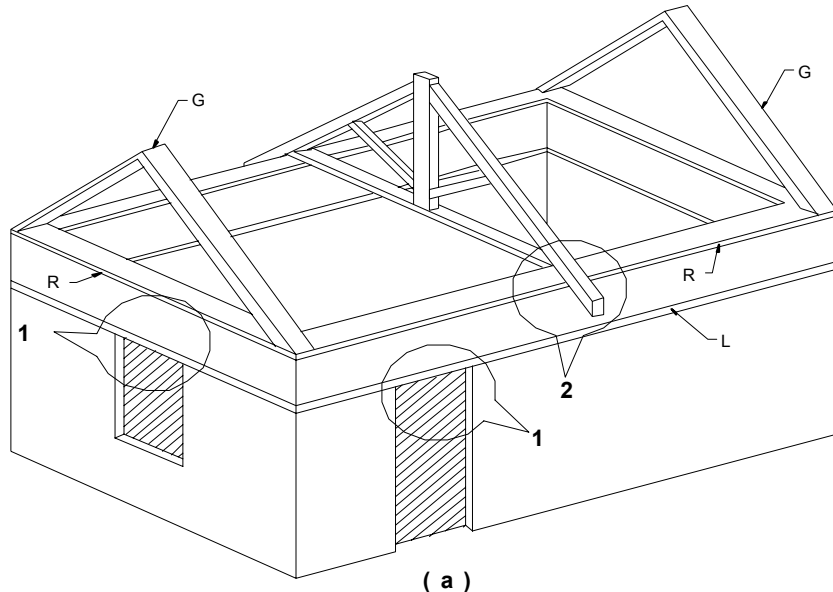

Note:

- i) As an alternative to the gable masonry, a truss or open gable may be used and the openings covered with a light material such as sheeting, matting etc.
- ii) If the wall-height up to eave-level is less than or equal to 2.5 m , the lintel-level band may be omitted and the lintel integrated with the eave-level band as shown in Detail 2.

Figure 8.2 : Overall Arrangement of Reinforcing Masonry Buildings

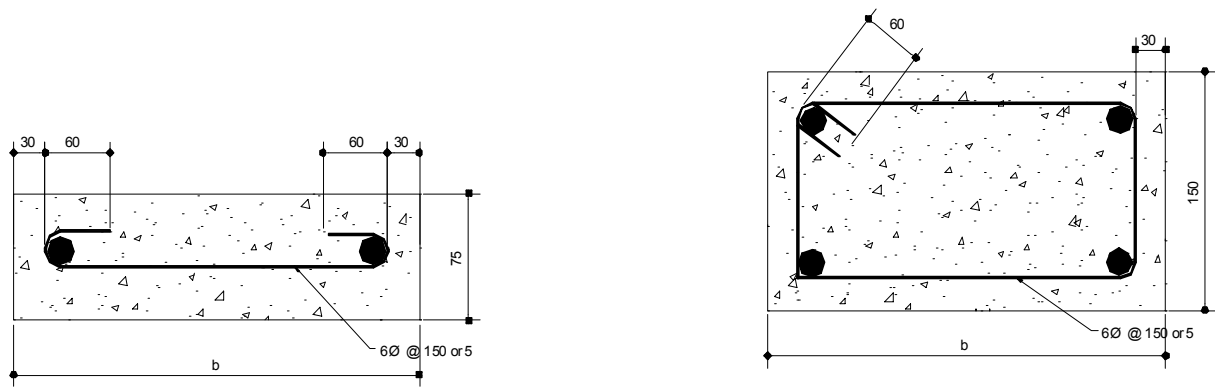

a) CROSS SECTION OF R.C.C. BAND FOR TWO BARS AND FOUR BARS

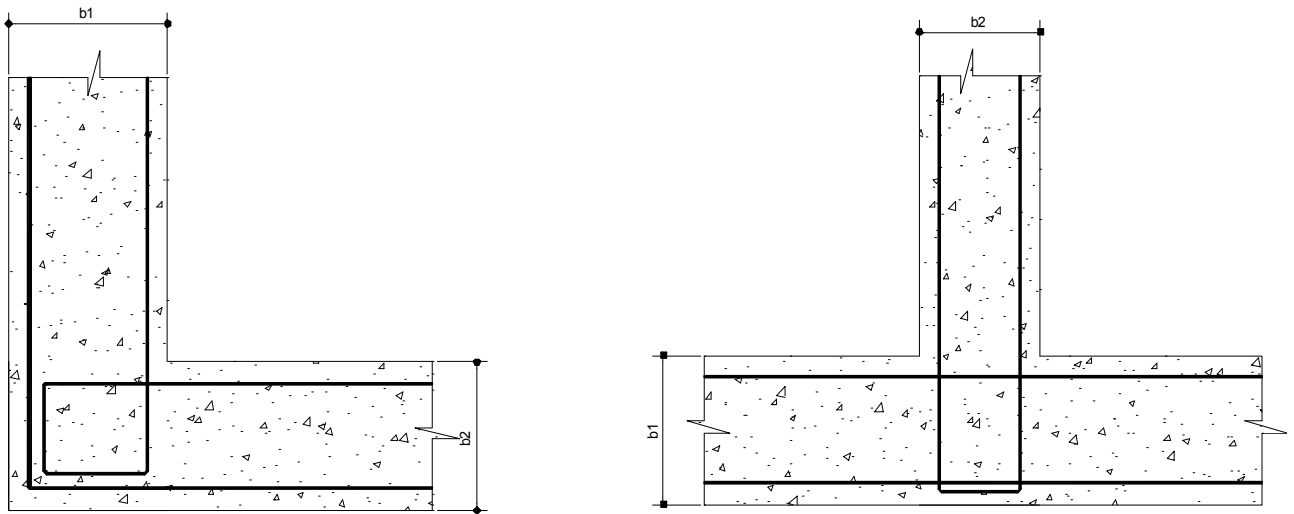

b) R. C. BAND REINFORCEMENT DETAILS AT CORNER AND T-JUNCTION

b, b_1, b_2 = Wall thickness
 Concrete (1:2:4) or 15 N/mm^2 cube compressive strength.

NOTE :

Provide overlaps for splicing bars outside the corner length of overlap to develop full band

Figure 8.3 : Reinforcement in RC Bands

9 Dowels at Corners and Junctions

Steel dowel bars shall be used at corners and T-junctions to integrate the box action of walls. Dowels (see **Figures 9.1, 9.2, 9.3 and 9.4**) are to be taken into the walls to a sufficient length so as to provide their full bond strength.

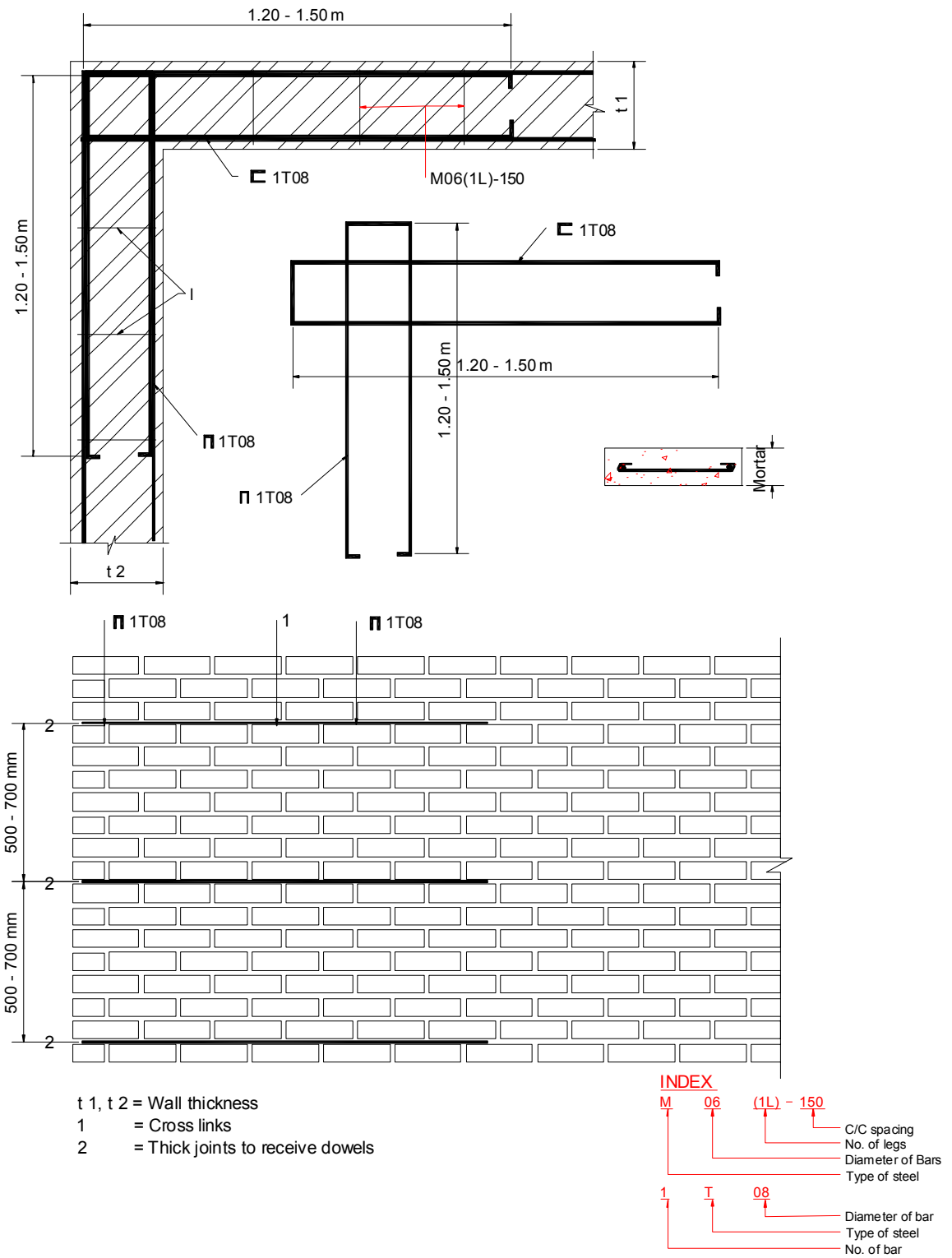

Figure 9.1 : Corner-Strengthening by Dowel Reinforcement Placed in One Joint

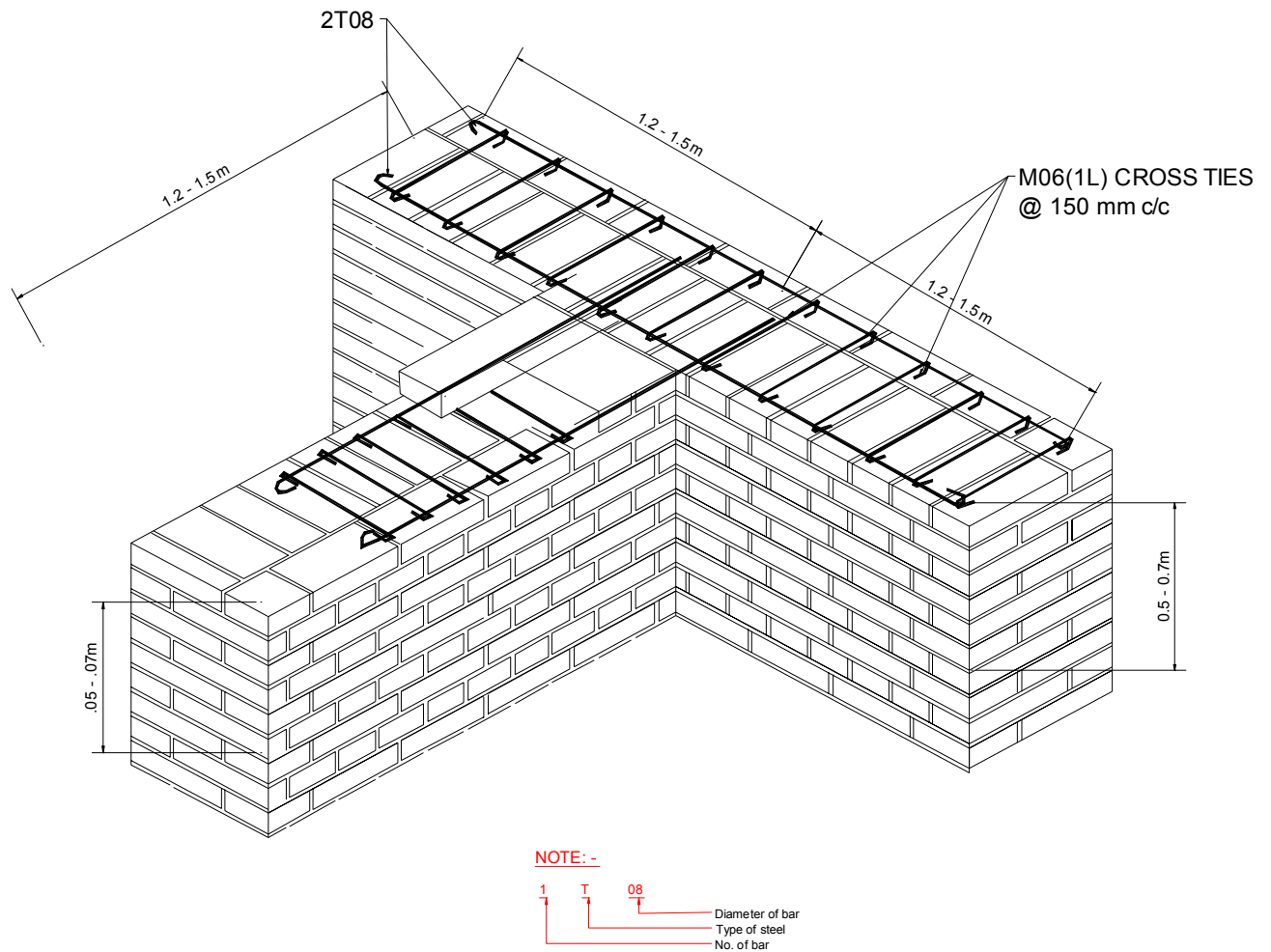

Figure 9.2 : Corner-Strengthening by Dowel Reinforcement Placed in Two Consecutive Joints

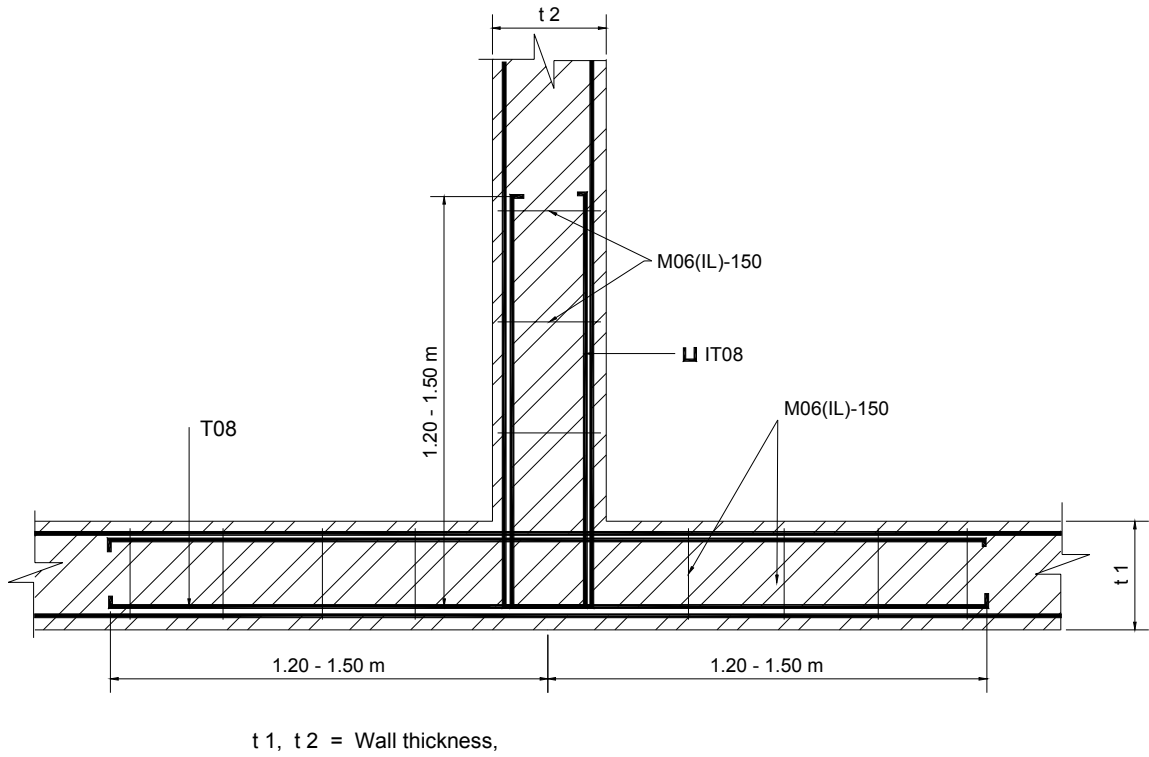

Figure 9.3 : T-Junction Strengthening by Dowel Reinforcing

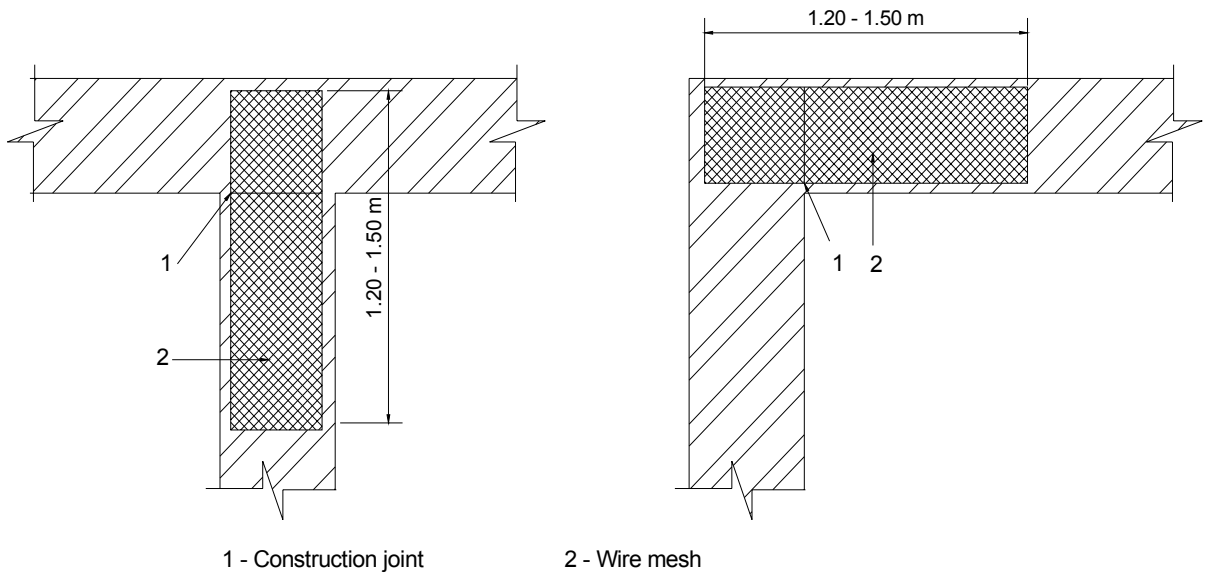
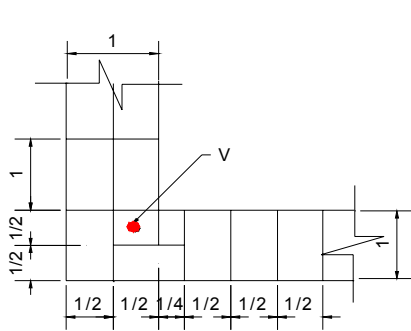

Figure 9.4 : Strengthening by Wire Fabric at Junctions and Corners

10 Vertical Reinforcement in Walls

Steel bars shall be installed at the critical sections (ie., the corners of walls, junctions of walls, and jambs of doors) right from the foundation concrete. They shall be covered with cement concrete in cavities made around them during the masonry construction (see **Figure 10.1**). This concrete mix should be kept to 1:2:4 by volume, or richer.

The vertical steel at openings may be stopped by embedding it into the lintel band, but the vertical steel at the corners and junctions of walls must be taken into either the floor and roof slabs or the roof band.



FIRST LAYER

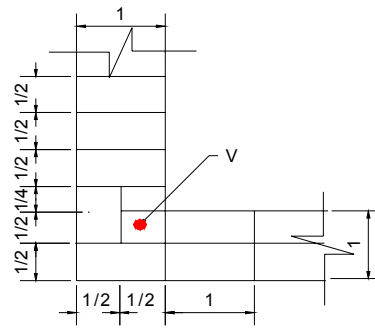

SECOND LAYER

CORNER JUNCTION DETAILS FOR ONE BRICK WALL FOR PROVIDING VERTICAL STEEL.

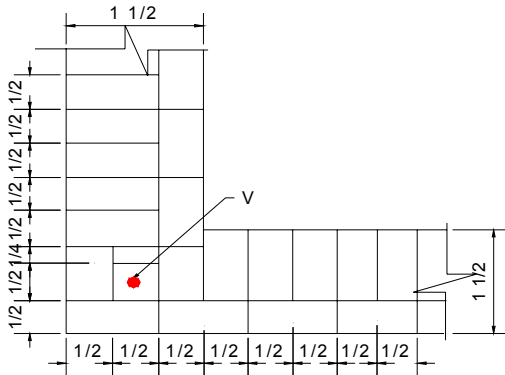

FIRST LAYER

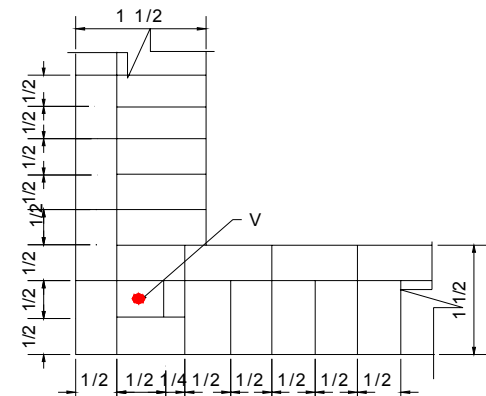

SECOND LAYER

CORNER JUNCTION DETAILS FOR ONE AND HALF BRICK WALL FOR PROVIDING VERTICAL STEEL.

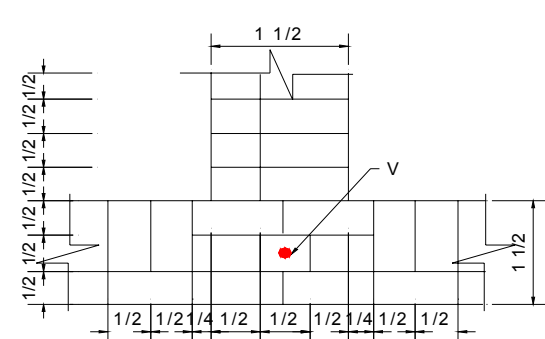

FIRST LAYER

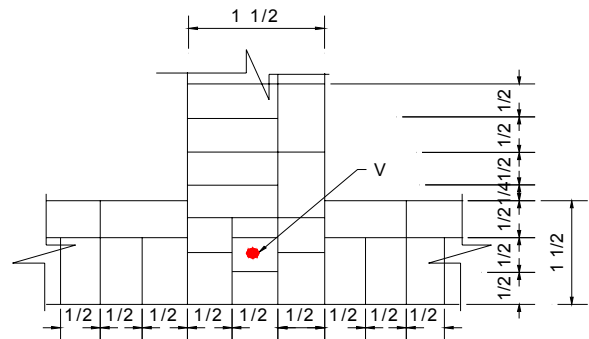

SECOND LAYER

T- JUNCTION DETAILS FOR ONE AND HALF BRICK WALL FOR PROVIDING VERTICAL STEEL.

1/4, 1/2, and 1 indicates: 1/4 Brick wide, 1/2 Brick wide, 1 Brick long etc.,
V - Vertical Bar

Figure 10.1 : Vertical Reinforcement in Walls

11 Roof

As a general rule, heavy roofs are a seismic hazard. Hence, roofs as well as floors should be made as light as structurally and functionally possible.

11.1 Pitched Roofs

Pitched roofs may be trussed, with the top of the walls generally at one level - except for the masonry gables at the ends of the building. Alternatively, the longitudinal and cross-walls may be raised to varying heights up to the roof slope and the rooms spanned by rafters and purlins. From a seismic design point of view, the trussed arrangement is preferable, particularly for school buildings.

11.2 Trussed Roofs

In trussed roofs, all trusses shall be supported on the eave or roof-band. Where a trussed roof adjoins a masonry gable, the ends of the purlins shall be carried on and secured to a plate securely bolted to the band at the top of gable-end masonry (**Figure 11.1**).

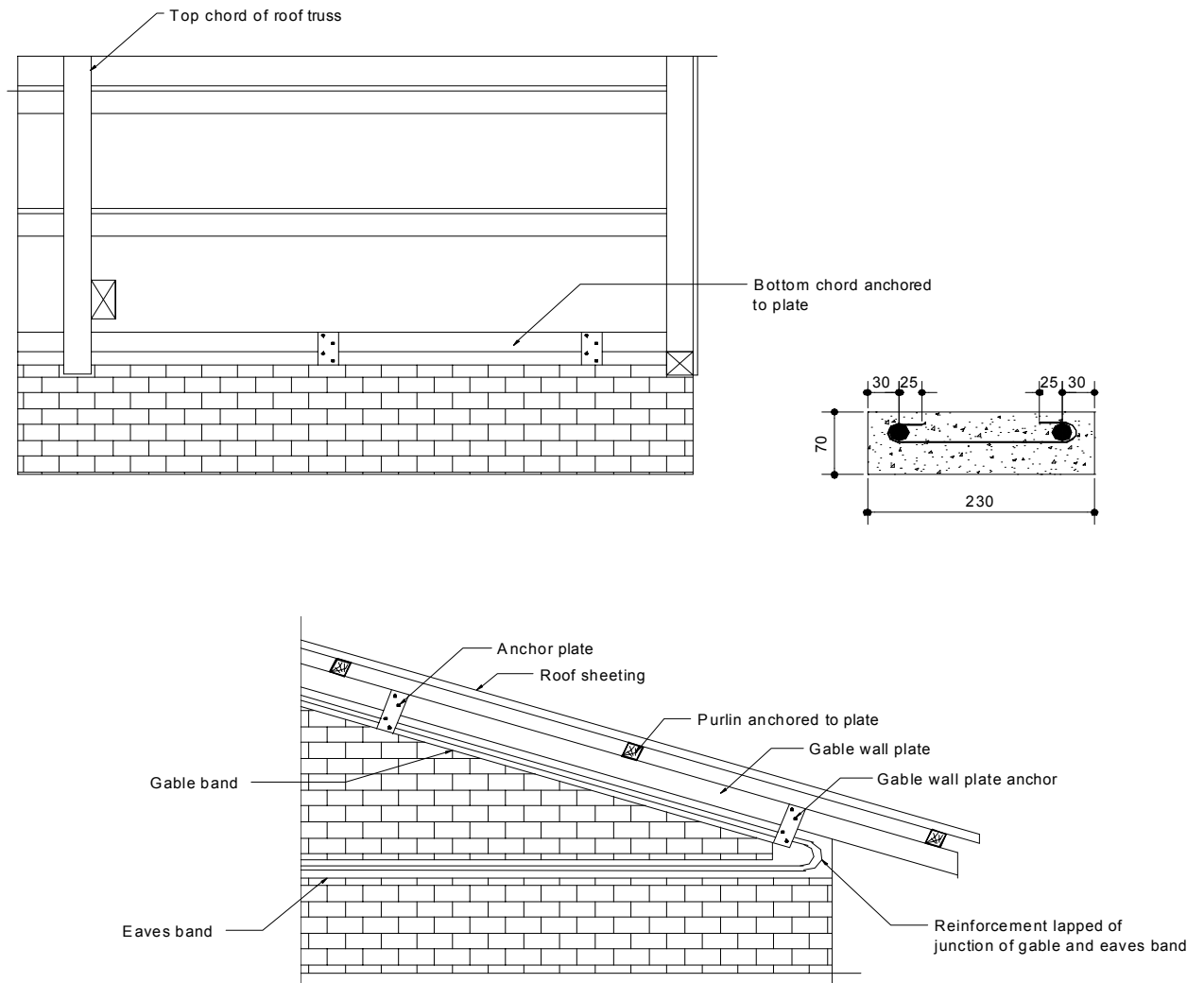

Figure 11.1 : Roof Fixing Details at Gables

11.3 Lean-to Roofs

All masonry walls shall be topped by a reinforced concrete roof-band securely held by means of bolts. Alternatively, wall plates may be used which are bolted to the band and to which the rafters and purlins are fixed (**Figure 11.2**).

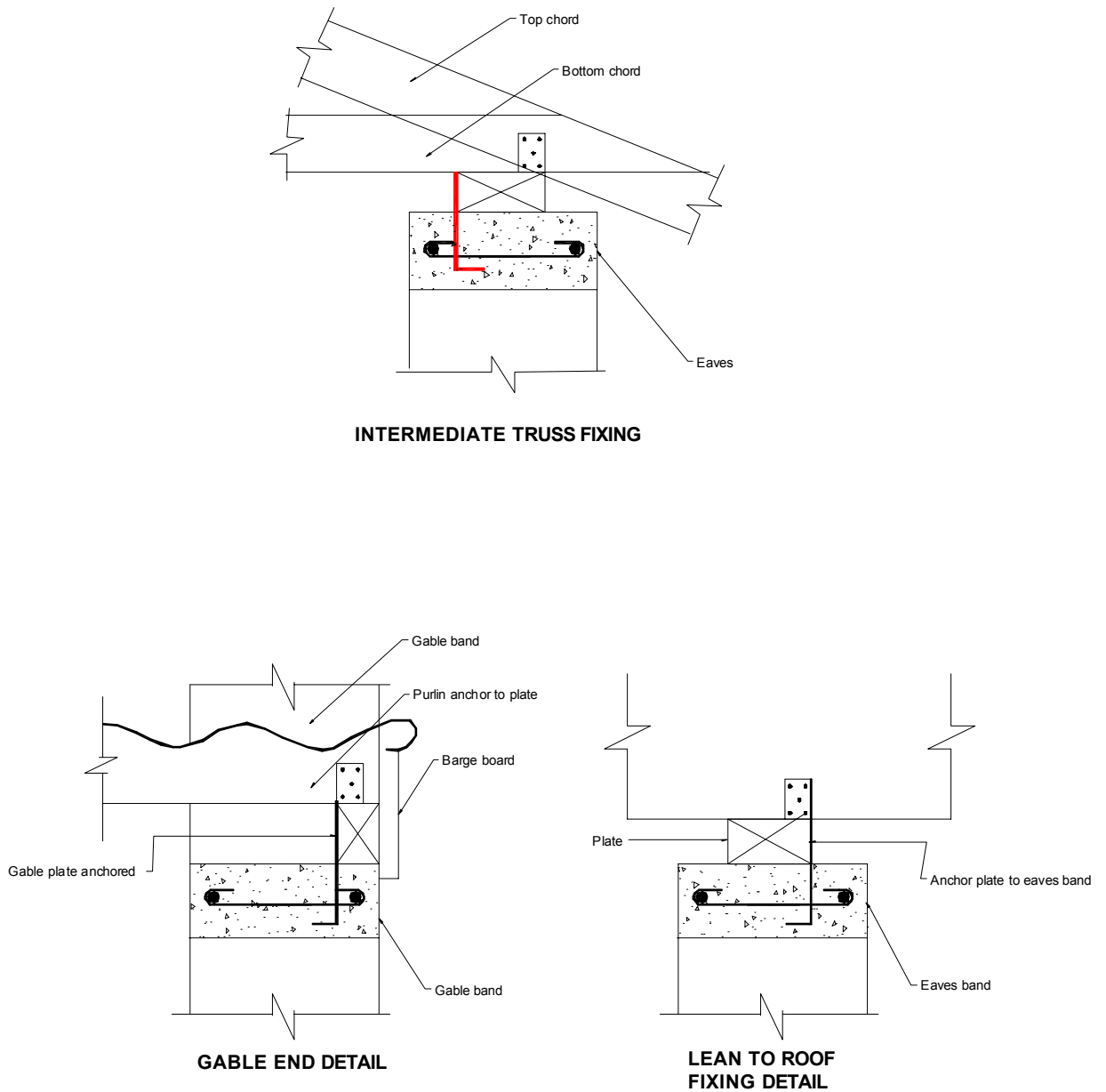

Figure 11.2 : Details for Fixing Roofs to Walls

12 Reinforcement Details for Hollow Block Masonry

The following details shall be followed in placing the horizontal and vertical steel in hollow block masonry using cement concrete blocks :

12.1 Horizontal Band

U-shaped blocks should be used for construction of the horizontal bands at various levels of the storey as per the seismic requirements shown in **Figures 12.1, 12.2** and **12.3**.

The amount of horizontal reinforcement may be taken as 25 % more than that given in **Table 12.1** and may be provided by using four bars and 6 mm diameter stirrups.

TABLE 12.1 : VERTICAL STEEL REQUIREMENT AT CRITICAL SECTIONS

No. of Storeys	Storey	Diameter of Fe 415 steel grade single bar in mm at each critical section for :		
		Category II	Category III	Category IV
One		10	10	Nil
Two	Top	10	10	Nil
	Bottom	12	12	Nil
Three	Top	10	10	Nil
	Middle	12	10	Nil
	Bottom	12	12	Nil

12.2 Vertical Reinforcement

The vertical bars specified in **Table 12.1** shall be located conveniently inside the cavities of the hollow blocks, one bar to each cavity. Where more than one bar is planned, these can be located in two or three consecutive cavities, as shown in **Figure 12.2**. The cavities containing bars are to be filled by using a concrete mix of (1:2:4) or a cement course-sand mortar (1:3), and are to properly rodded for compaction.

To avoid the need to lift blocks too high, the bars are made shorter and lapped with upper bars. This is wasteful of steel and has a second disadvantage in that the capacity to develop sufficient bond strength in small cavities remains doubtful. To solve this problem, the two alternatives shown in **Figure 12.3** may be used :

- (a) the use of three sided or U-blocks
- (b) bent interlocked bars

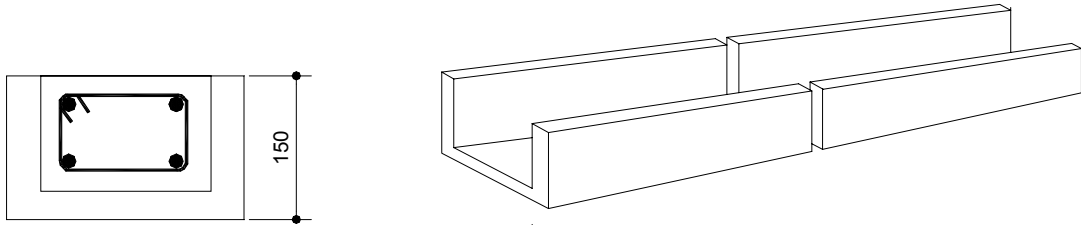

Figure 12.1 : U-Blocks for Horizontal Bands

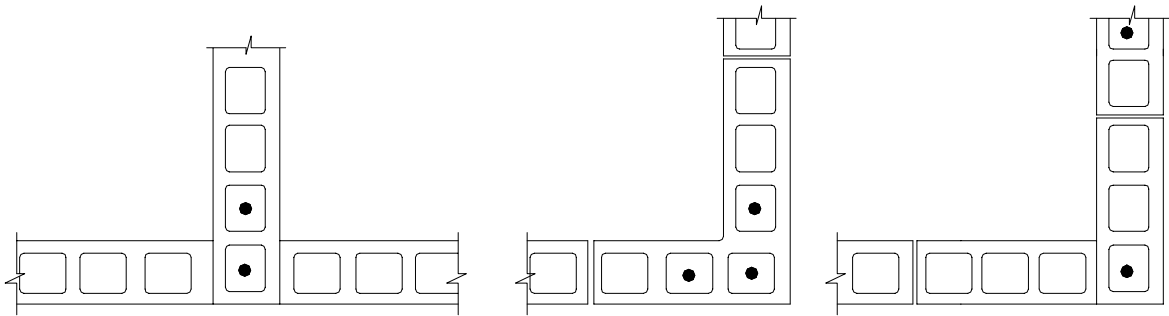

Figure 12.2 : Vertical Reinforcement in Cavities

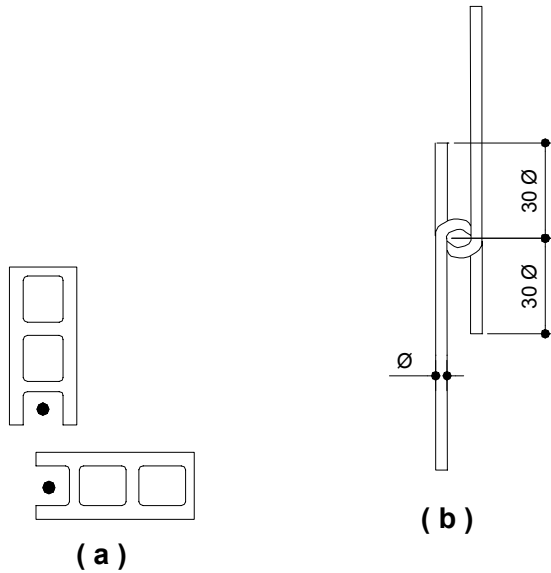

Figure 12.3 : Vertical Reinforcement in Cavities

MANDATORY RULE OF THUMB FOR STONE MASONRY BUILDINGS
(Up to two-storeyed buildings in cement mortar,
one and a half-storey buildings in mud mortar)

13 Overall Dimensions

The height of stone buildings constructed to this MRT is restricted to two storeys only. However, an attic floor may also be used within the building. The inter-storey height may be kept as low as 2.5 m, but not more than 3.2 m. The maximum unsupported length of a wall (long wall) between cross-walls shall be limited to five metres. For longer walls, buttresses shall be used at intermediate points not further apart than three metres. Each buttress shall have a minimum thickness at its base of one-sixth of the wall height and a minimum thickness at its top equal to the thickness of the wall it supports.

14 Openings in Walls

Openings should be as small and as centrally located as practicable. The required limits on opening size are shown in **Figure 14.1**. Ventilators, where used, shall be 450 x 450 mm or smaller.

Tops of openings in a storey should preferably be at the same level, so that a continuous band can be provided over them that includes the lintels throughout the building.

The horizontal distance between two openings shall not be less than one-half of the height of the shorter opening.

The vertical distance between openings one above the other shall not be less than 600 mm.

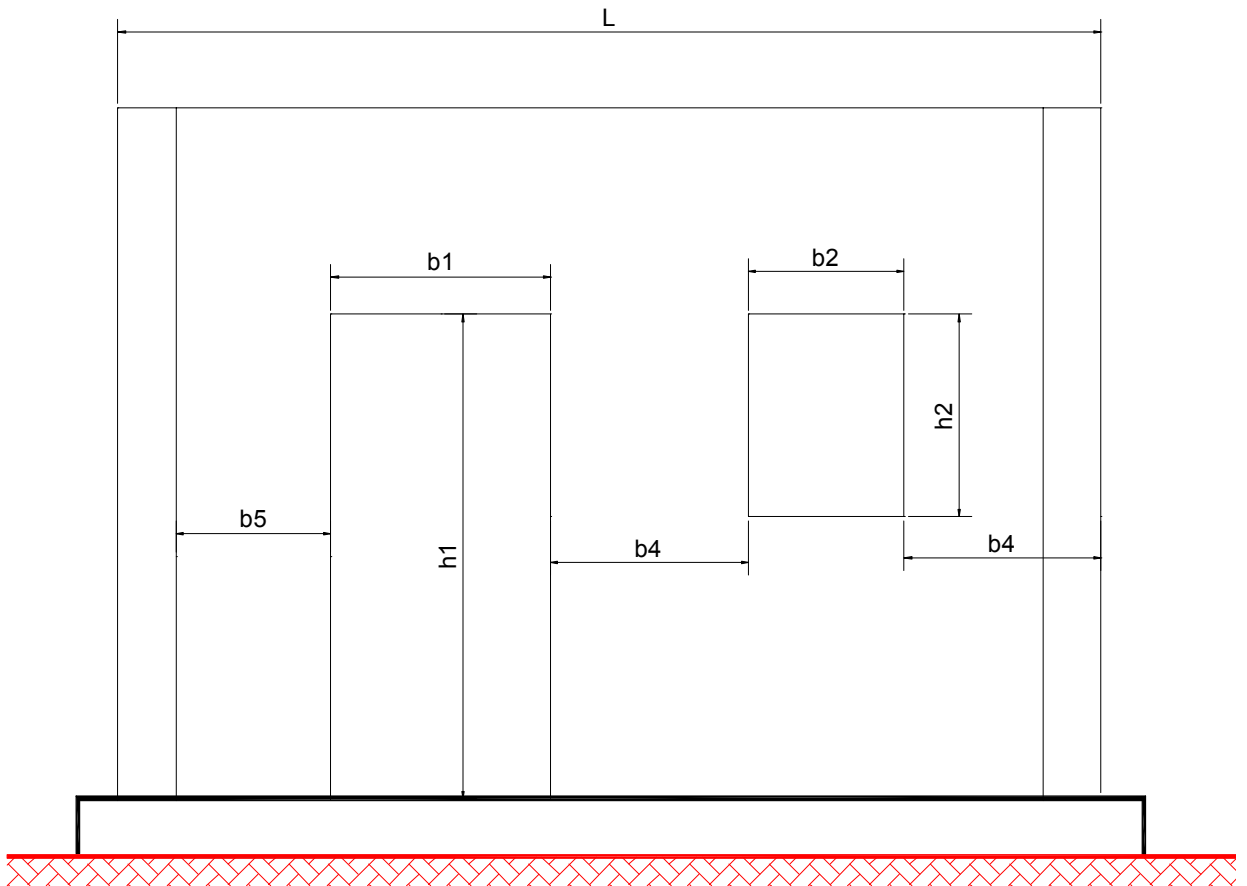
**NOTE:**

$$b_1 + b_2 < 0.3 L$$

$$b_4 > 0.5 h_2 \text{ but not less than } 600 \text{ mm.}$$

$$b_5 > 0.25 h_1 \text{ but not less than } 600 \text{ mm.}$$

Figure 14.1 : Recommended Openings in Load-Bearing Rubble Masonry

15 Masonry Bond

Random rubble masonry construction should be constructed in lifts of not more than 600 mm.

THROUGH-STONES of a length equal to the full wall thickness should be used in every 600 mm lift at not more than 1.2 m apart horizontally. If full-length stones are not available, pairs of stones, each about three-quarters of the wall thickness long, shall be used in place of one full-length stone so as to provide an overlap between them (see **Figures 15.1** and **15.2**).

Alternatively, wooden bars at least 38 mm x 38 mm in cross-section, or equivalents, may be used instead of through-stones. The wood shall be well-preserved through seasoning and chemical treatment so as to be durable against both weathering action and insect attack as in **Figure 15.2**.

Long stones shall also be used at corners and junctions of walls to break the vertical joint pattern and to provide bonding between adjacent walls.

15.1 Mortars and Concrete

Where steel reinforcing bars are provided, the bars shall be embedded in a cement-sand mortar not leaner than 1:4, or in a cement concrete mix of (1:2:4) (Grade M15).

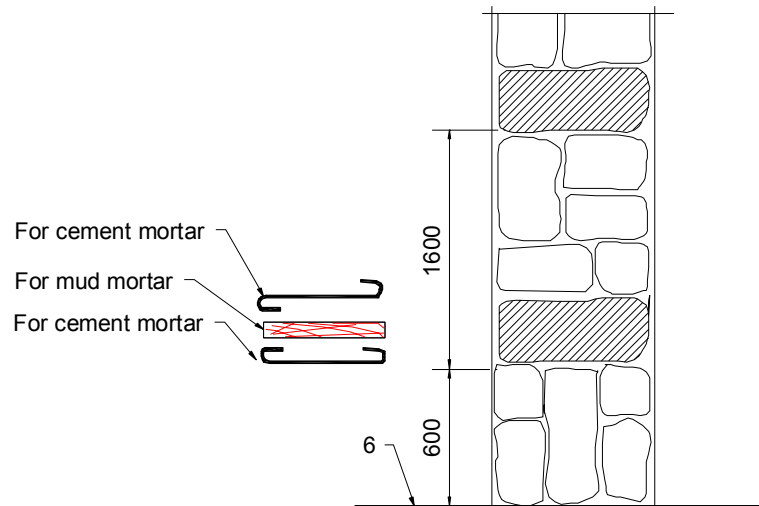
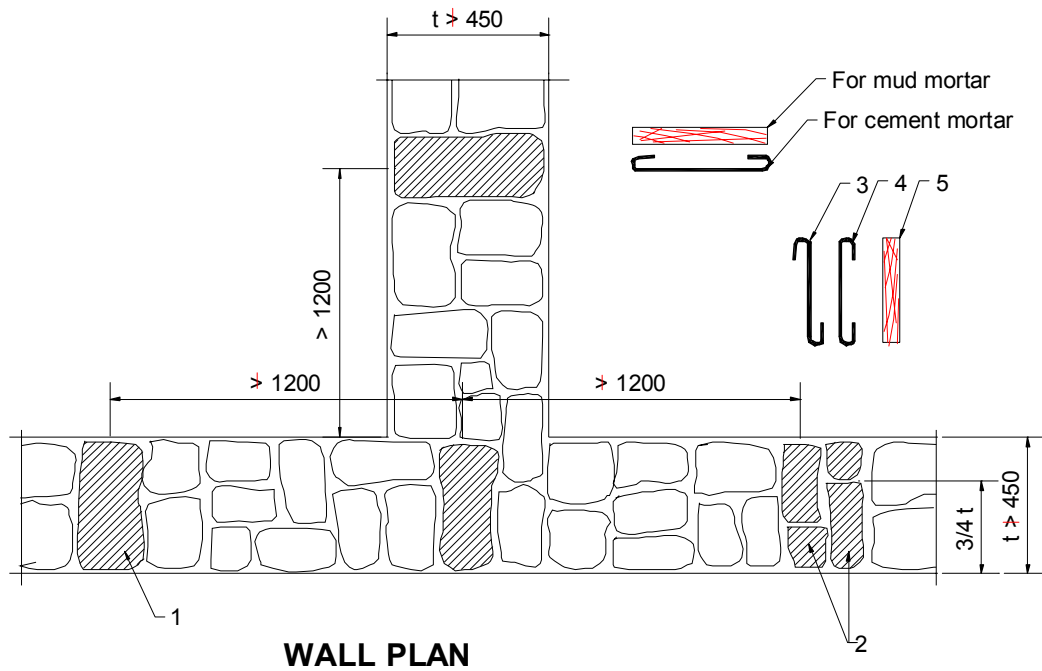

- 1 - Band stone, 2 - Pair of overlapping stones, 3 - S shape tie,
- 4 - Hooked link, 4 - wood plank, 6 - Floor level.

NOTE:

In band stone not available then provide wood piece 38 x 38 or steel bar 8 mm diameter in the stone wall.

Figure 15.1 : 'Through' Stones or Bond Elements

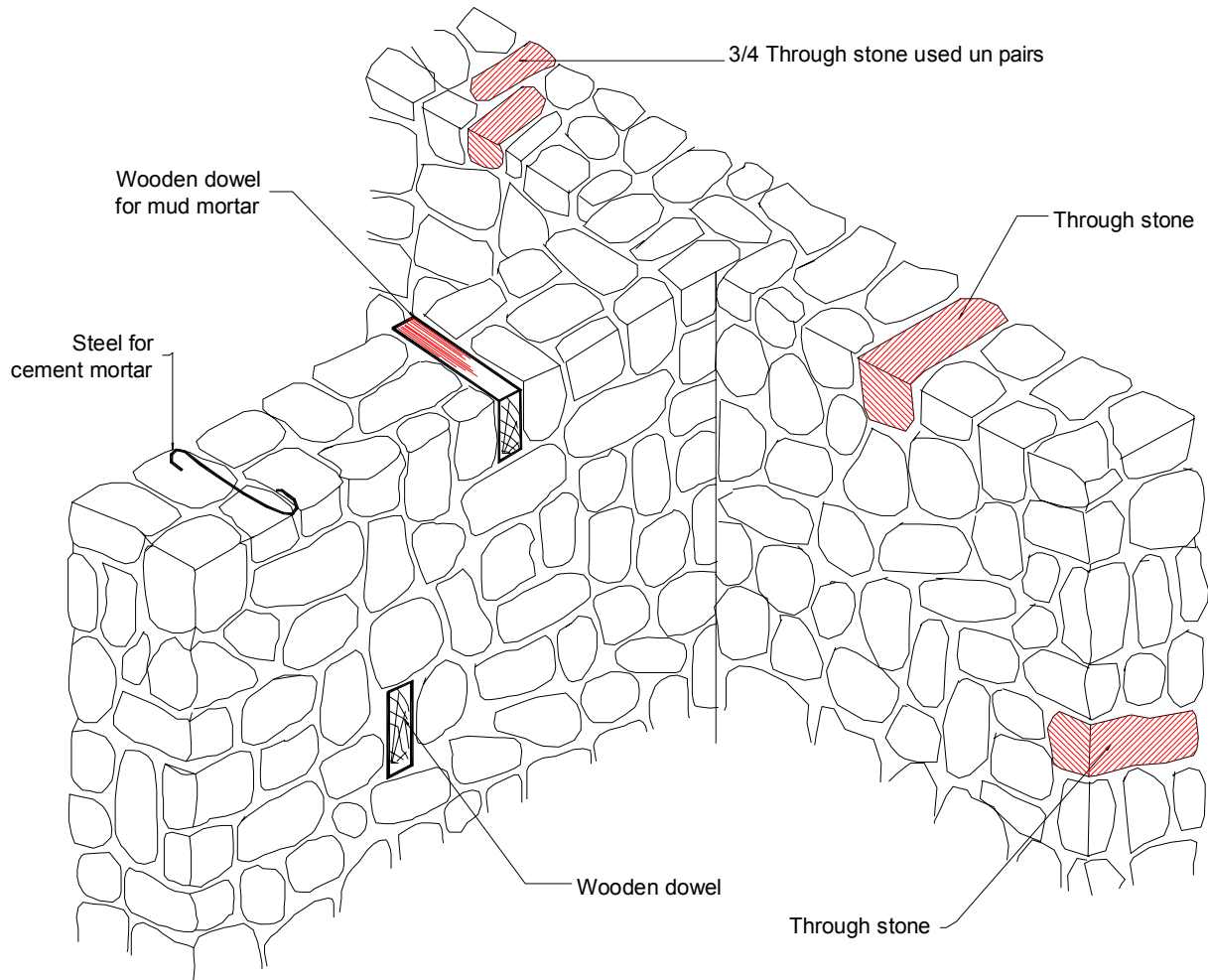
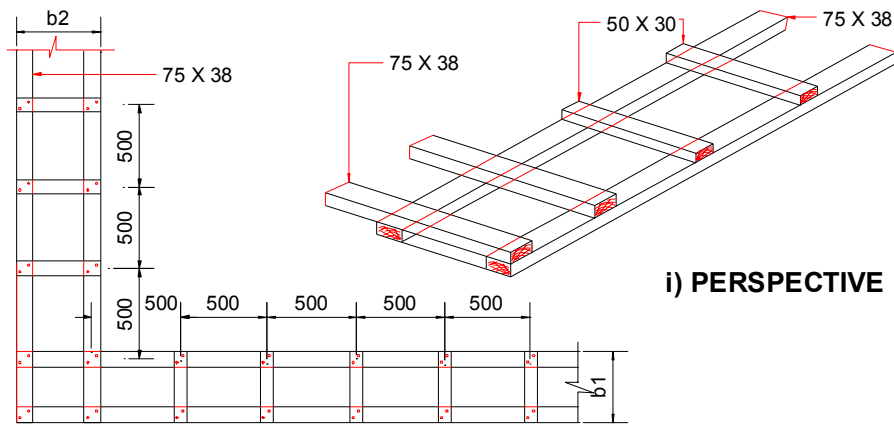

Figure 15.2 : Random Rubble Masonry with Through-Stones or Other Bonding Elements

16 Horizontal Reinforcement in the Walls

All the horizontal reinforcing recommended for brick buildings in **Section 7** shall be used for random rubble construction as well.

As an alternative to steel reinforcing bars, wooden planks of rectangular section, effectively spliced longitudinally and held by lateral members in a lattice form, may be used where timber is available and more economical, as shown in **Figures 16.1** and **16.2**.



$b_1, b_2 =$ Wall thickness

Figure 16.1 : Lintel-Level Wooden Band on all Load-Bearing Walls

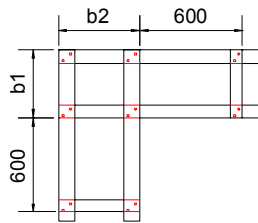

i) WOOD DOWEL AT CORNER OF WALL

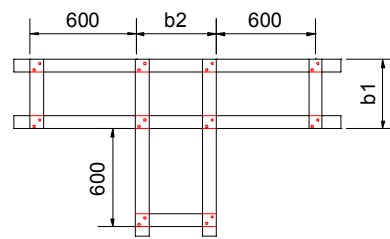

ii) WOOD DOWEL AT T-JUNCTION OF WALL AT ABOUT 900 ABOVE FLOOR LEVEL

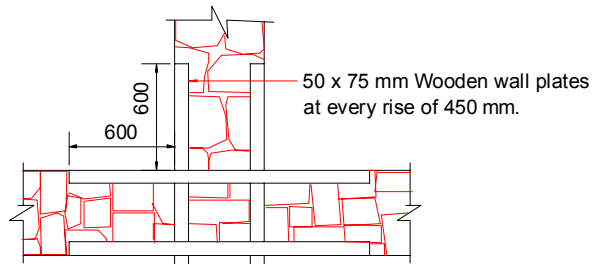

Figure 16.2 : Details of Wood Reinforcing at Corners (for Mud Mortars)

17 Vertical Reinforcement in Walls

The amount of vertical reinforcement required to be provided in masonry walls at the corners and T-junctions and at jambs of openings is shown in **Table 17.1**.

TABLE 17.1 : REQUIRED VERTICAL STEEL AT CRITICAL SECTIONS

No. of Storey	Diameter of Fe550 Single Bars in mm at each critical section for Category*		
	Category II	Category III	Category IV
One	12	10	Nil
Two	12	12	Nil

* Category I is covered by Draft Nepal Standard NBC 109.

Notes :

- (1) *Two-storeyed buildings with load-bearing stone masonry of random rubble or half-dressed stone are not recommended for Category II.*

The installation of a vertical bar in stone masonry can easily be effected by using a 75 mm diameter pipe casing around which the masonry is built to a height of 600 mm and 75 mm diameter. The pipe is kept loose by rotating it during masonry construction. Then the casing is raised up and the cavity filled around the bar with concrete (1:2:4) as shown in **Figures 17.1** and **17.2**. The concrete will not only provide a bond between the steel and the masonry, but it will also protect the bar from corrosion.

The jamb steel shall be taken from the footing up to the lintel band and anchored into it.

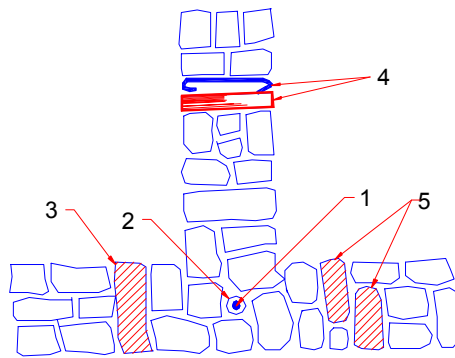

1 - Vertical steel bar, 2 - Casing pipe, 3 - through stone,
4 - stone or wood link, 5 - Over lapping pair of stones.

Figure 17.1 : Vertical Steel in Random Rubble Masonry

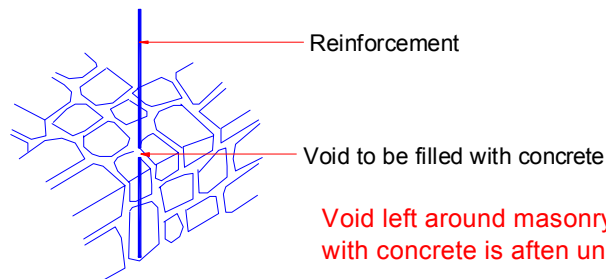

Void left around masonry to be filled with concrete is often unsatisfactory.

75 mm. Ø Int.dia.x 60 cm. long pipe sleeve

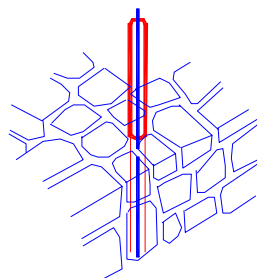
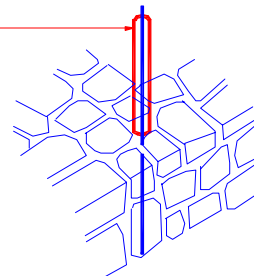

Use of pipe sleeve to create uniform void for reinforcement as per following steps :

1. Place pipe sleeve around reinforcement.
2. Build masonry around the pipe sleeve.
3. Lift the pipe sleeve leaving hollow in masonry.
4. Fill the void with mixed concrete and coarse aggregate 10 mm.
5. Repeat process.

Figure17.2 : Vertical Reinforcement in Rubble Stone Masonry

**MANDATORY RULE OF THUMB FOR BRICK MASONRY BUILDINGS
CONSTRUCTED IN MUD MORTAR**

18 Width of Footing

The width of the strip footing for the wall shall be made as shown in **Figure 1.3**.

19 Height of Wall

The height of the wall shall not be greater than eight times its thickness.

20 Openings in Walls

Openings shall be as small and as centrally-located as practicable. The recommended opening limits are shown in **Figure 20.1**. Ventilators, where used, shall be made 450 mm x 450 mm or smaller.

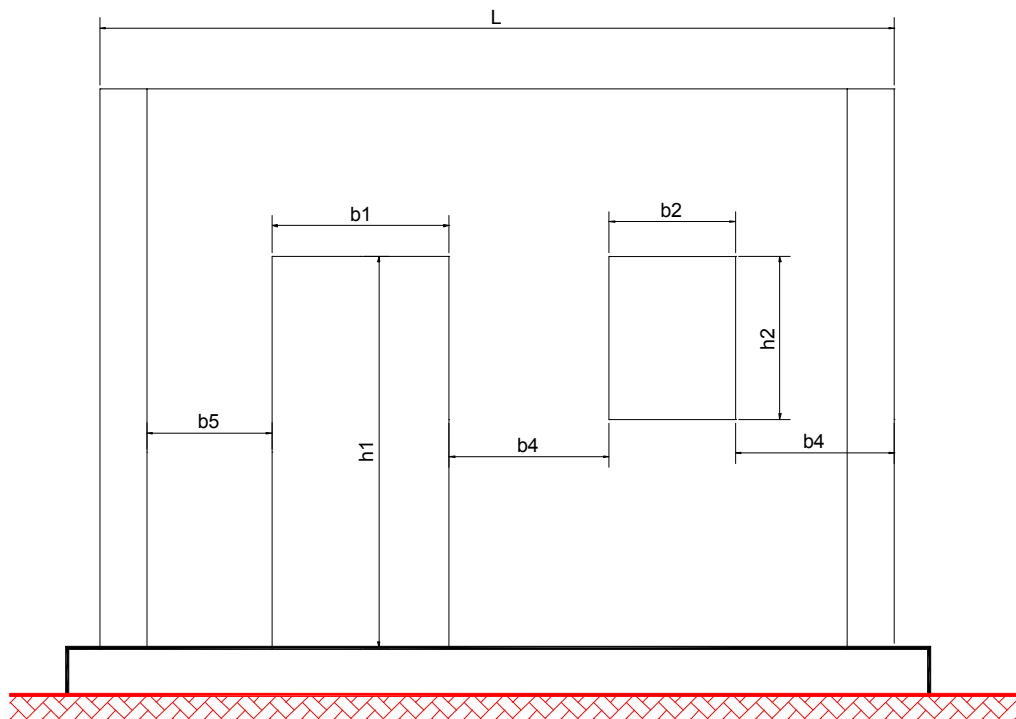

NOTE:

$$b1 + b2 < 0.3 L$$

$$b4 > 0.5 h2 \text{ but not less than } 600 \text{ mm.}$$

$$b5 > 0.25 h1 \text{ but not less than } 600 \text{ mm.}$$

Figure 20.1 : Maximum Opening Sizes in Bearing Walls in Brick in Mud Mortar

Tops of openings in a storey should preferably be at the same level, so that a continuous band can be provided over them, including the lintels throughout the building.

The horizontal distance between two openings shall not be less than one-fourth of the height of the shorter opening.

The vertical distance between openings one above the other shall not be less than 600 mm.

21 Bearing Length

The bearing length (embedment) of a lintel on each side of an opening shall not be less than 300 mm.

22 Collar Beams or Horizontal Bands

- (i) Unfinished rough-cut timber in single pieces provided with diagonal members for bracing at corners (see **Figures 22.1a, 22.1b and 22.2**).
- (ii) Unfinished rough-cut or sawn (50 mm x 100 mm section) timber, two pieces in parallel with halved joints at corners and junctions of walls, placed in parallel (see **Figures 22.1a, 22.1b and 22.2**).
- (iii) A RC horizontal band that is compatible with the above timber ones.

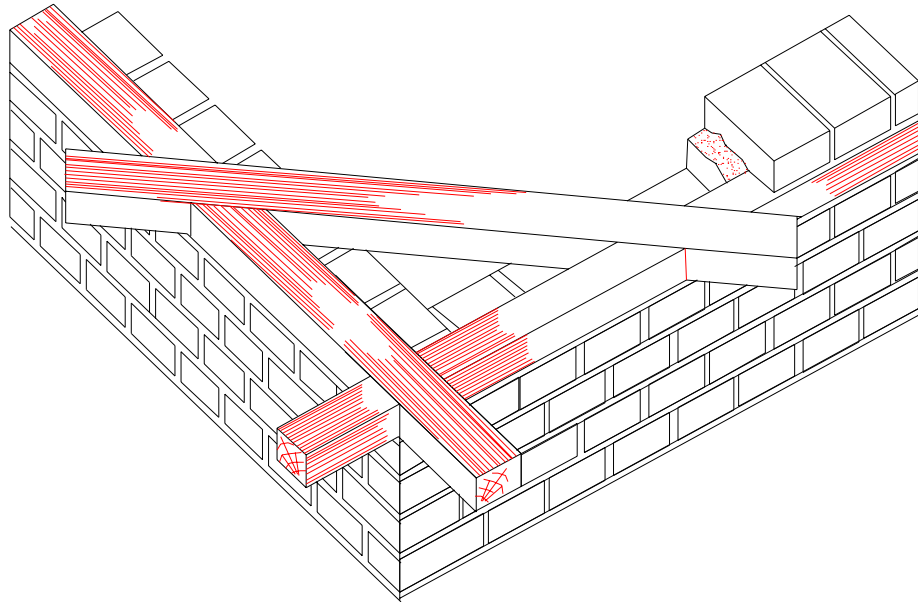

(a) Rough-Cut Timber in Single Pieces with Corner Diagonal

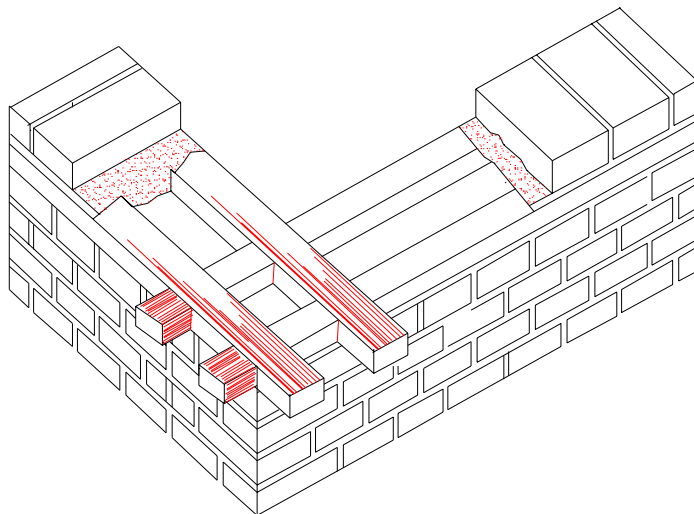

(a) Rough-Cut Timber in Parallel

Figure 22.1 : Collar Band in Wall at Lintel-Level

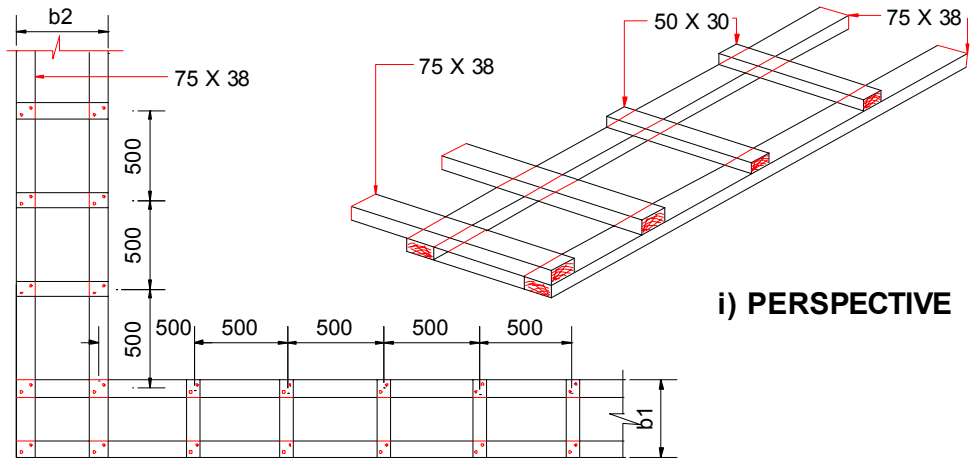

$b_1, b_2 =$ Wall

Lintel-Level Wooden Band on all Load-Bearing Walls

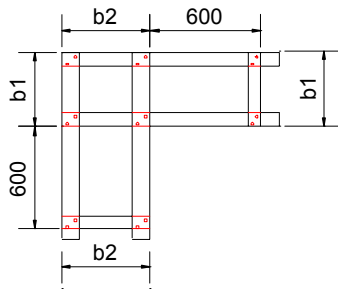

i) WOOD DOWEL AT CORNER OF WALL

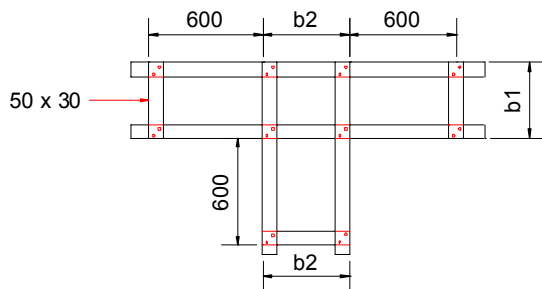

ii) WOOD DOWEL AT T-JUNCTION OF WALL AT ABOUT 900 ABOVE FLOOR LEVEL

Figure 22.2 : Details of Timber Reinforcing at Corners and T-Junctions

23 Pilasters and Buttresses

Where pilasters or buttresses are used as recommended at T-junctions, the collar beam should cover the buttress as well, as shown in **Figures 23.1, 23.2 and 23.3**. The use of diagonal struts at corners will further stiffen the collar beam.

TABLE 23.1 : THICKNESS AND SPACING OF STIFFENING WALLS

No. of Storeys	Thickness of Load-Bearing Wall to be Stiffened	Height* of Storey not to Exceed	Buttress or Stiffening Wall Thickness, not Less than (for 1 to 2 storeys)
	mm	M	mm
1	230	3.2	340
2	340 (I Storey)	3.2	340
	230 (II Storey)	3.2	340

* Storey heights and maximum spacings given are centre-to-centre dimensions.

24 Vertical Wood or Bamboo Reinforcement in the Walls

- (i) The whole wall should be reinforced by a means of bamboo along with collar beams which may, in this case, be made from bamboos themselves. The vertical bamboo or canes must be tied to the horizontal bamboo as well as to the collar beams at lintel-level, and to the roof beam at eave-level.
- (ii) The most effective vertical reinforcement in the case where cement concrete and steel reinforcement is not available, is in the form of wooden posts, or bamboo, located at the corners and junctions of walls. It should be started at the foundation level and continued through and tied to the lintel and roof-bands with binding wires, fishing-line or rope, etc.

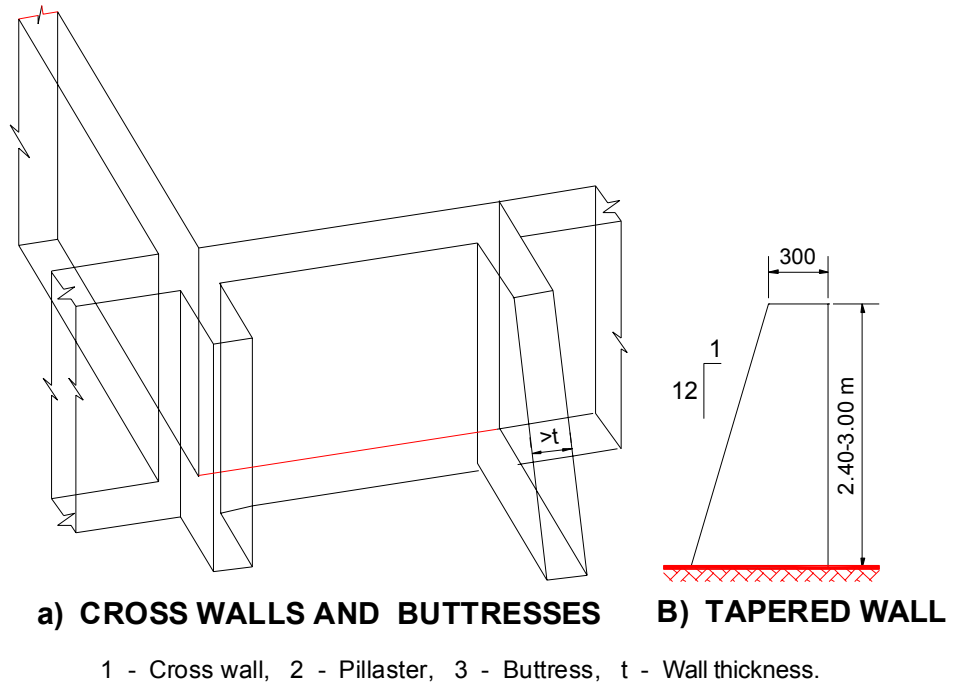

Figure 23.1 : Wall Dimensions

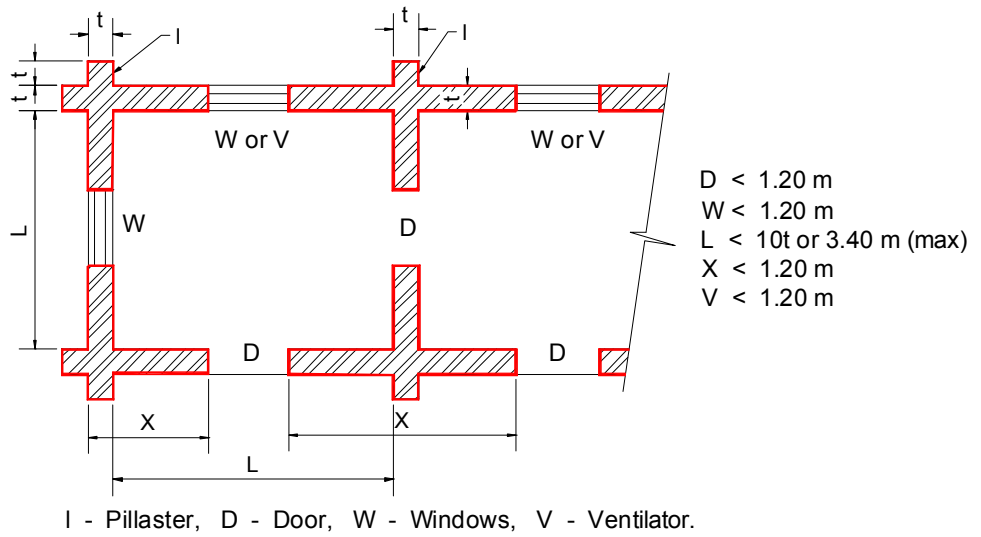

Figure 23.2 : Pillasters at Corners

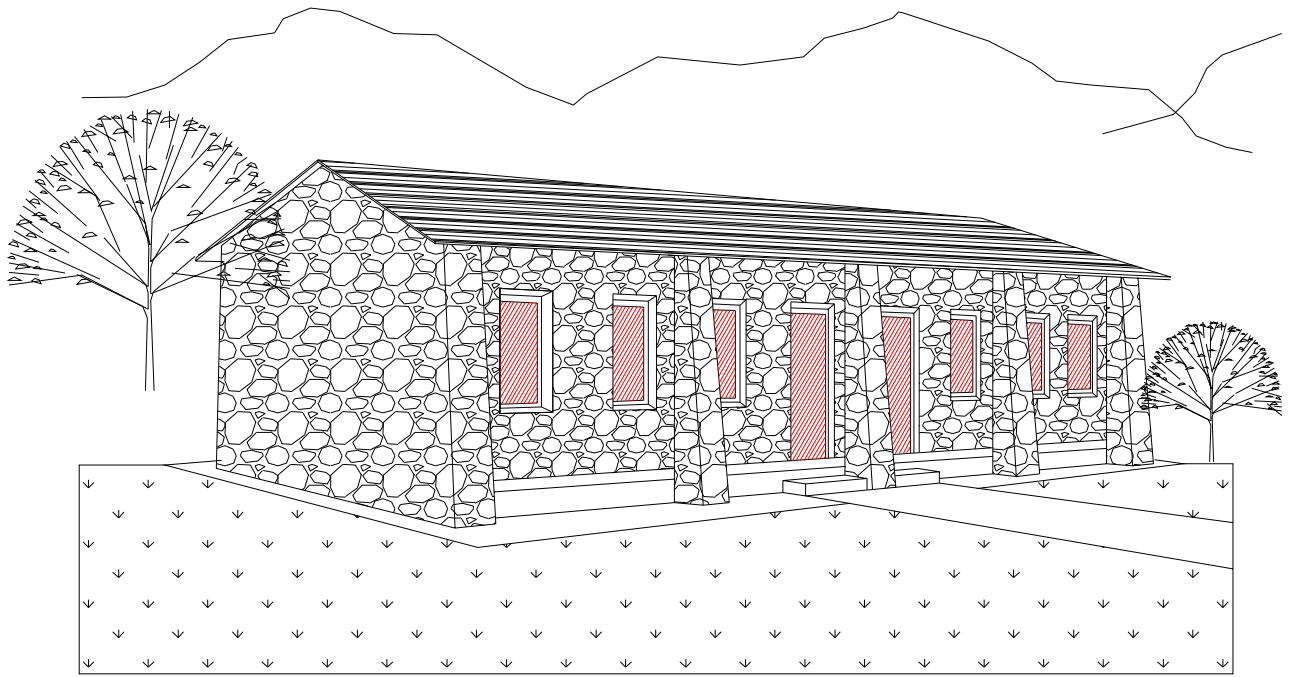
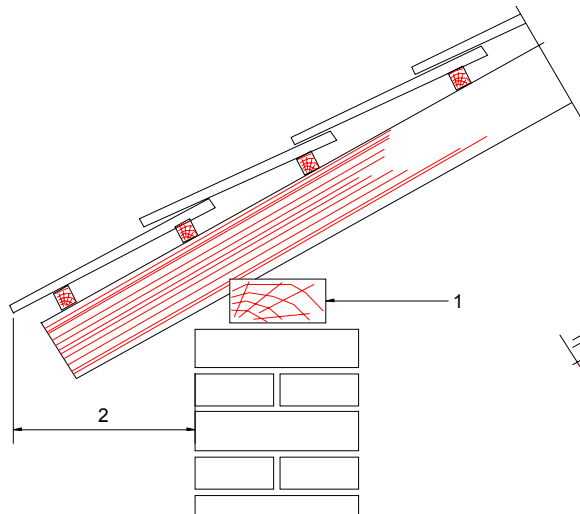

Figure 23.3 : Correctly Buttressed Single-Storey School-Building

25 Roofing

The roofing structure must be light, well-connected and adequately tied to the walls :

- i) The roof beams, rafters or trusses should preferably be supported on longitudinal wooden elements for distributing the load on mud walls (**Figure 25.1**).
- ii) The roof beams or rafters should be located so as to avoid their being placed above door or window lintels. Otherwise, the lintel should be reinforced by an additional piece of timber (**Figures 25.2 and 25.3**).



- 1. - Longitudinal wood element (wall plate).
- 2. - Rain protection overhang about 500 mm.

a) USE OF LONGITUDINAL WOOD UNDER ROOF RAFTER

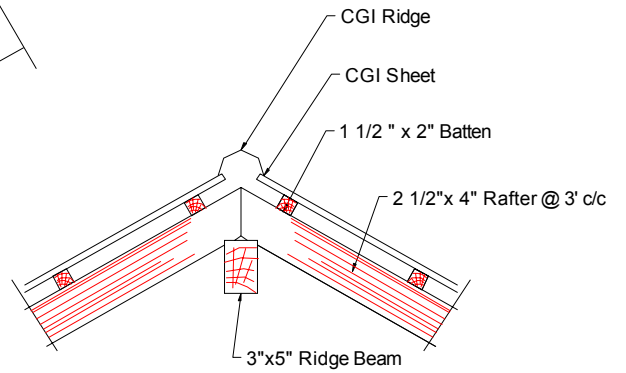

b) RIDGE DETAIL

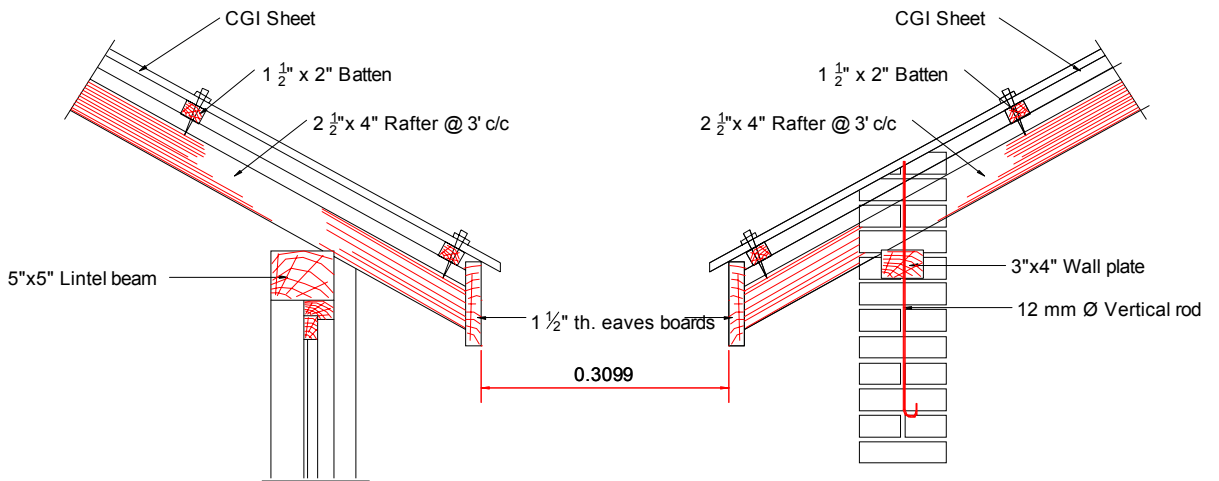

c) ROOF AND LINTEL DETAIL

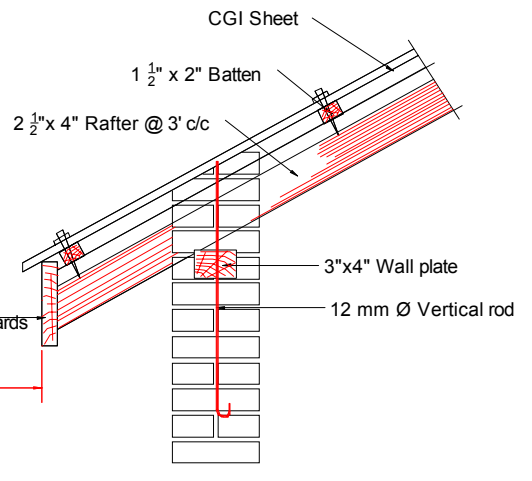

d) WALL AND ROOF DETAIL

Figure 25.1 : Support Details for Roofing

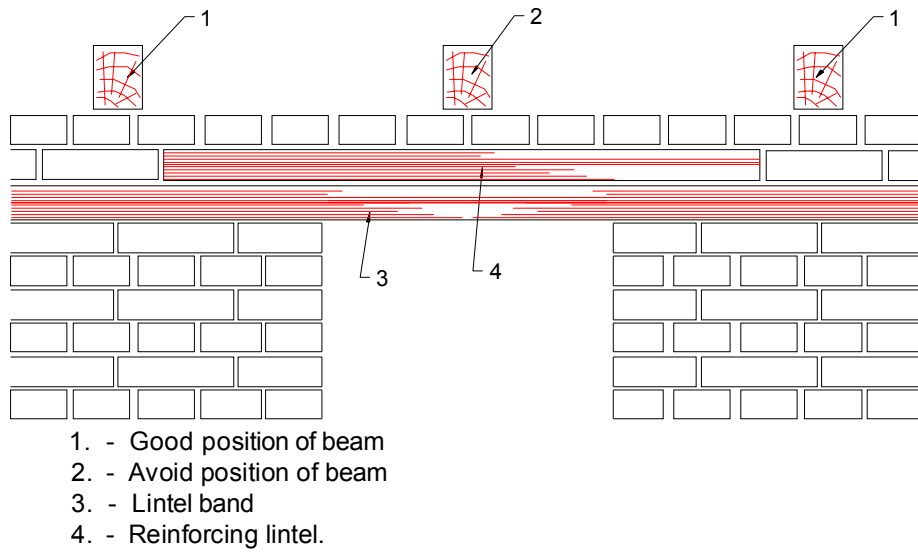

Figure 25.2 : Reinforcing Lintel Under Floor Beam

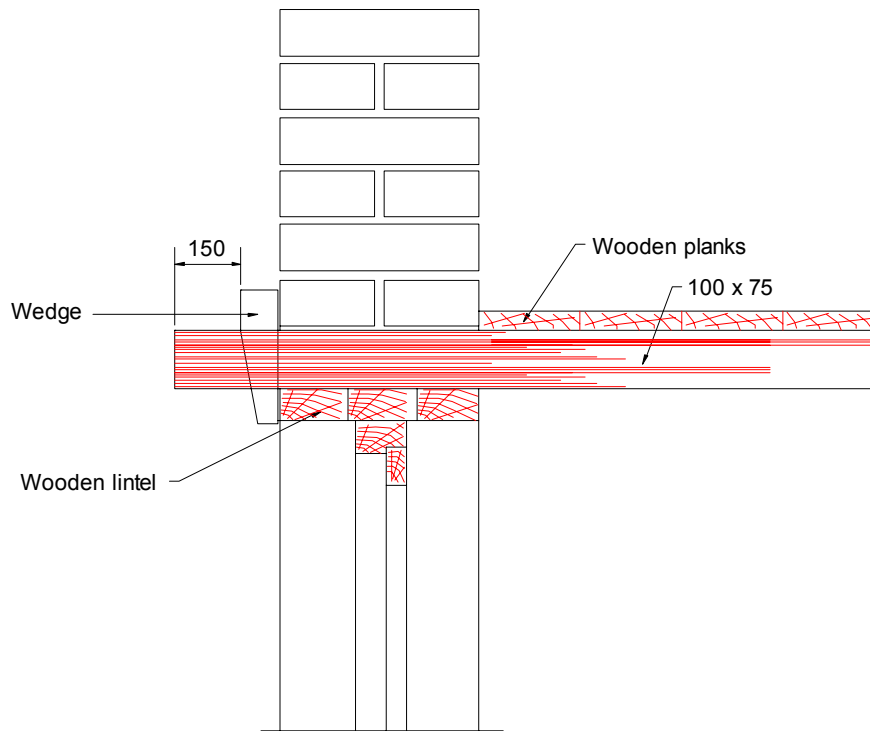

Figure 25.3 : Lintel and Floor Joint Detail